

PRODUCT SPOTLIGHT

STAR FASTENERS

The Huck® Penta-Lok® Lightweight Panel Fastener Innovation in fastening technology

The Huck Penta-Lok structural fastener has come to the market driven by the need for a fastener specifically designed for the lightweight panel market; a material used increasingly in the manufacturing sector. Thanks to its high pull-out strength, Penta-Lok is suited for use within thin materials or delicate composites.

We recognised a gap in the market for a mechanical blind fastener that can be quickly installed in the multiple variations of sandwich, ridged and composite panels. The ever-evolving lightweight panels are being used in a wide range of applications. Star Fasteners specific focus was to fasten LoadLok® / load restraint systems and other components to the lightweight

panels used in the commercial vehicle market.

Penta-Lok's reduced flange diameter allows installation against raised profiles and has been specifically designed for the secure fastening of profiled cargo load restraint and areas with restricted space, such as door gear and latches.

"The Huck Penta-Lok is an easy-to-install, 6.4mm diameter, all steel (body and mandrel) plated, peel structural fastener with superior blind side strength. It has a neat domed head and its positive mechanical pin retention ensures structural integrity. It has been designed as an efficient and effective fastener; when cargo

is locked and secured to the sub frame of a trailer or train waggon it experiences high environmental stresses, so the fastener needs to be robust and work hard" says Dan Starbuck.

Penta-Lok's uniquely engineered peel system installs with ease into shallow panels. If the tip of the body is inserted into material (minimum 8mm composite / honeycomb / foam core panel) the Penta-Lok will do the rest. The installation process seats the flange to the surface of the material as it claws itself in on the blind side; resulting in a supportive load spread of approximately 16mm.

"In our experience, installation into Alucore®, Cortinium® and other well know brands of lightweight, ridged, high-performance panels has been extremely successful.

Huck Range
Force™
Battery Tool



“

The Huck Penta-Lok is an easy-to-install, 6.4mm diameter, all steel (body and mandrel) plated, peel structural fastener with superior blind side strength.



Huck Penta-Lok key feature, wide load spread (installed blind-side view)

Huck Penta-Lok
6.4Ø all steel
structural fastener

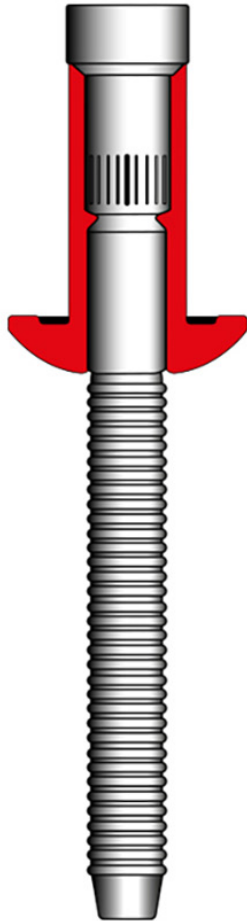

Huck Penta-Lok Cross Section

These panels clearly have weight advantages, they have become the go-to choice for commercial vehicle manufacturers, driven in-part for the need to cut weight and ultimately Co2 emissions. The panel market is evolving at a fast pace with a wide range of options available. Vehicle manufacturers can now offer their customers a choice of material, sandwich composition, performance, sizes and finishes. Customers want the flexibility to specify the lightest, the most resilient to



damage or recyclable options available, so it made sense to design a strong fastener that works and performs well in a broad spectrum of plastic, honeycomb aluminium and multi composite boards," says Starbuck.

Used within the correct grip it does not dent the sandwich panel or pull through the material. Penta-Lok has the advantage over adhesives in that it is fast to install, particularly if installed with Huck's new Range Force lightweight battery tool. It is a perfect fastener to use in conjunction with adhesives and sealants. Using the Huck Penta-Lok in key areas of a build enables quick panel stability; no need for as many clamps or tape and the project can immediately be moved onto the next production process allowing the adhesive

to effectively cure. In a fully recyclable panel such as Technolite® which has an aluminium honeycomb core and faced with aluminium sheet, Penta-Lok offers a secure fastening solution that can also be recycled when it reaches the end of its useful life. The longevity of a finished product is undoubtedly connected to the quality of materials used. Huck fasteners are a proven, versatile, quality fastening solution.

As well as being the largest UK stockist of the Huck® fastener brand and an authorised tool service and repair workshop, Star Fasteners stock a comprehensive range of rivets. These include standard, sealed, multi-grip and many specials for bespoke applications and are available in a wide range of materials and finishes. An in-house powder coating service ensures that any stock item can be coloured to meet customers' requirements and despatched at short notice. For more information on our complete range of services go to www.starfasteners.co.uk

Email: sales@starfasteners.co.uk
Tel: +44 (0)1159 324939

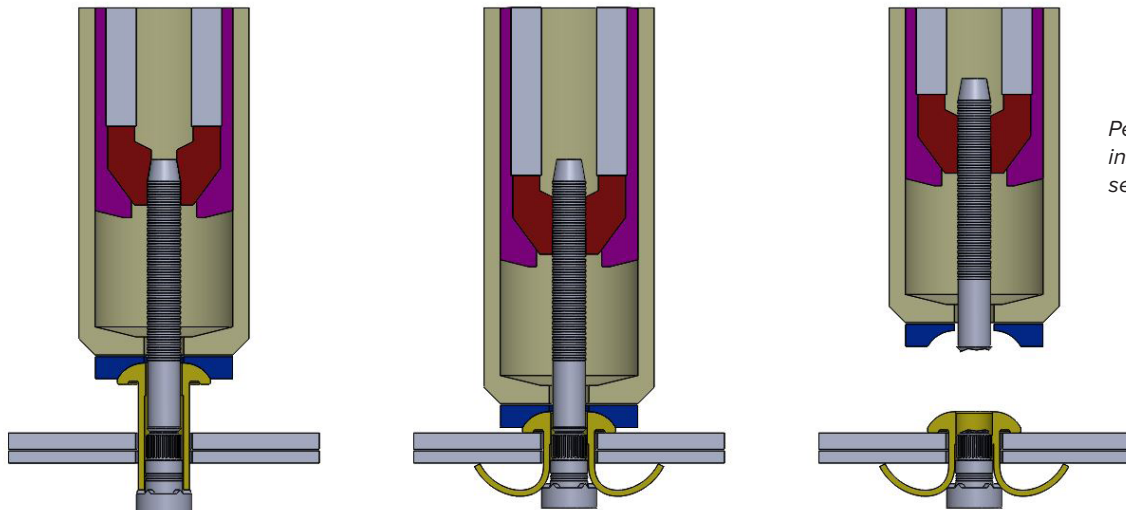

Penta-Lok installation sequence