

Huck® Structural Blind Fasteners

Stainless Steel Auto-Bulb™



Attractive, rounded bulbing on blind side minimises snag risk

Tapered tip: for easy introduction into the blind hole

Large blind side footprint: ideal for lower strength or thin sheet joint material

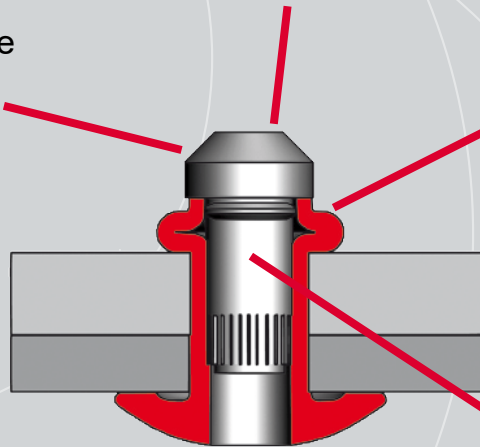

Recessed pin break on installation side means less risk of catching clothes or skin or the installed fastener

High corrosion resistance: stainless steel (400) enables use in applications operating in corrosive or hygienic environments including white goods and agriculture

Typical values

Shear: 15.1 kN

Tensile: 8.45 kN

Pin retention: 1.33 kN

| Part Number | Diameter (mm) | Min. Hole size (mm) | Max. Hole size (mm) | Min. Grip (mm) | Max. Grip (mm) | Nom. F (mm) | Nom. L (mm) |
|-------------|---------------|---------------------|---------------------|----------------|----------------|-------------|-------------|
| ABP-4U8-M2 | 6.4 | 6.63 | 6.91 | 1.5 | 3.5 | 15.05 | 10.85 |
| ABP-4U8-M3 | 6.4 | 6.63 | 6.91 | 2.8 | 4.8 | 16.35 | 12.15 |
| ABP-4U8-M4 | 6.4 | 6.63 | 6.91 | 3.8 | 5.8 | 17.35 | 13.15 |
| ABP-4U8-M5 | 6.4 | 6.63 | 6.91 | 4.8 | 6.8 | 18.35 | 14.15 |
| ABP-4U8-M6 | 6.4 | 6.63 | 6.91 | 5.8 | 7.8 | 19.35 | 15.15 |
| ABP-4U8-M7 | 6.4 | 6.63 | 6.91 | 6.8 | 8.8 | 20.35 | 16.15 |
| ABP-4U8-M8 | 6.4 | 6.63 | 6.91 | 7.8 | 9.8 | 21.35 | 17.15 |
| ABP-4U8-M9 | 6.4 | 6.63 | 6.91 | 8.8 | 10.8 | 22.35 | 18.15 |
| ABP-4U8-M10 | 6.4 | 6.63 | 6.91 | 9.8 | 11.8 | 23.35 | 19.15 |
| ABP-4U8-M12 | 6.4 | 6.63 | 6.91 | 11.8 | 13.8 | 25.35 | 21.15 |
| ABP-4U8-M19 | 6.4 | 6.63 | 6.91 | 18.8 | 20.8 | 32.35 | 28.15 |

