

# THE HUCK® FLOORTIGHT®

STAR FASTENERS

## EASY TO INSTALL BLIND RIVET DESIGNED FOR PLYWOOD AND PLYMETAL APPLICATIONS

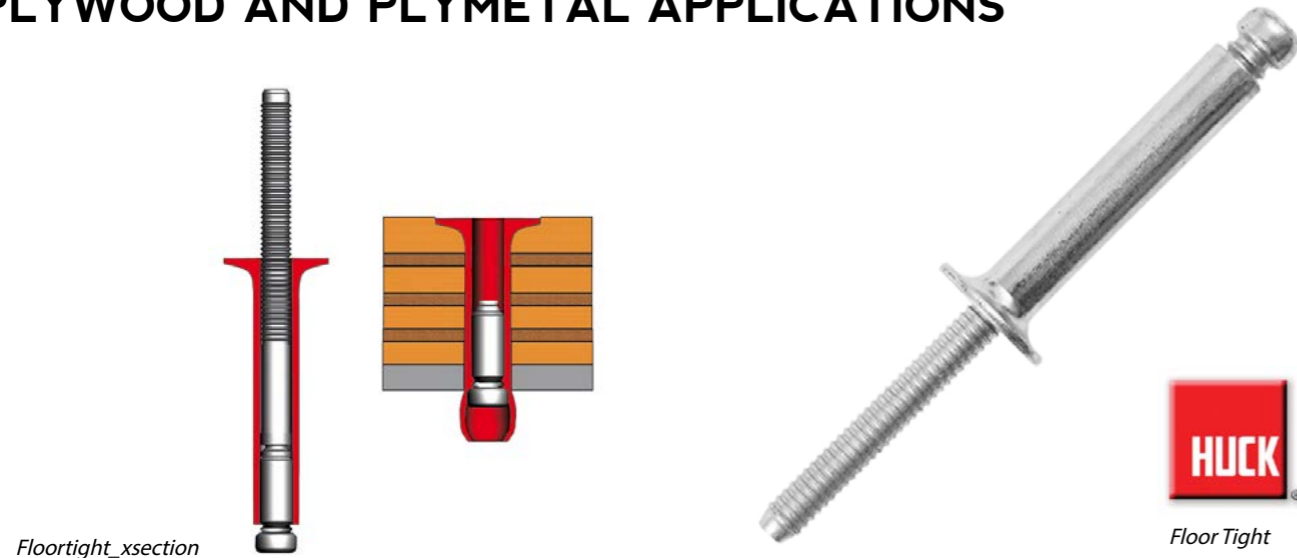

Due to their cost effectiveness and versatility in so many applications, blind structural faster technology has become an essential part of many modern industrial production processes. Huck FloorTight is an ideal blind fastener for all wood to metal applications. For example, "In plywood and plymetal vehicle floor applications, you need a fastener that's strong, vibration resistant and watertight. Just as importantly, you want a fastening system that's designed to reduce installation costs" adds Dan, MD at Star Fasteners.

### WHY USE A STRUCTURAL FASTENER?

The presence of the mandrel accounts for a 60-80% increase in load-carrying ability in shear and tensile over conventional non-structural blind fasteners. Structural blind fasteners can be differentiated from non-structural not only by their overall increased level of strength, but also by the fact that their published shear values will be higher than their tensile values.

Historically the Huck FloorTight has been specifically designed for use in vehicle flooring manufacturing. However, it is not its only use "we are seeing it used in quite innovative applications including commercial vehicle trailer internal walls, fastening ply to steel uprights. We recently helped specify the FloorTight into a large heavy-duty trailer where the load, due to its awkward size and weight, was buffeting the trailer side making the existing screw heads raise and break-away, which then snagged and damaged its contents". The FloorTight fastener offers

superior strength to conventional flooring screws and reduces the number of fasteners required and thereby the number of drilled holes. With various clamp strengths available, it is proving to be a popular fastening solution.

Available Sizes: 1/4", 5/16"

Materials: Steel

Headstyles: Standard, Wide Flange, Plymetal, 90° Countersunk

### WHAT ARE THE BENEFITS OF USING A HUCK FLOORTIGHT FASTENER?

- Installing Huck FloorTight fasteners means the only labour required is one person to drill the hole and install the fastener. It is a one-sided installation process
- Its self-countersinking feature eliminates the secondary counter boring process in plywood. Across a job it adds up to huge time savings. An extremely strong fastener installed with one less step!
- FloorTight uses the force of the mandrel pulling up from the blindside to form a bulbing footprint, which stops the fastener pulling through and securely clamps the materials, whereas self-threading screws only rely on the thread cut into the steel as their anchor point.
- A large grip range eliminates the guesswork. The FloorTight fastening system accommodates material thickness ranging from 19.1mm to 41.3mm. The fasteners offer high clamp, high tensile and high shear

strength and when used in a commercial vehicle application it helps to eliminate the shifting and buckling of a trailer floor.

- Watertight. Unlike ordinary nuts and bolts, the FloorTight fastener is watertight on the blind side, preventing moisture from entering through the body of the installed fastener.
- Superior performance, time after time. When it comes to holding power, FloorTight never gives up. Its design eliminates overtorque, screw head-poppers and loosening common in conventional floor screws.
- There are Numerous Health and safety benefits using the Huck FloorTight blind fastener. The installation process is easy on the ears and the environment. All Huck fasteners use quiet, non-torque tools for lower noise. And health risks are reduced because operator muscles and joints are not subjected to the constant torque of power tools.
- The engineer can be sure each FloorTight fastener has been installed correctly every time".

Specialists in the supply and distribution of Huck Fasteners, Star Fasteners proud to be the UK's largest Huck fastener stockists. Working with a diverse range of end users and distributors from across a number of industries including rail, solar, wind power automotive, marine and the commercial vehicle market.

## Huck FloorTight®

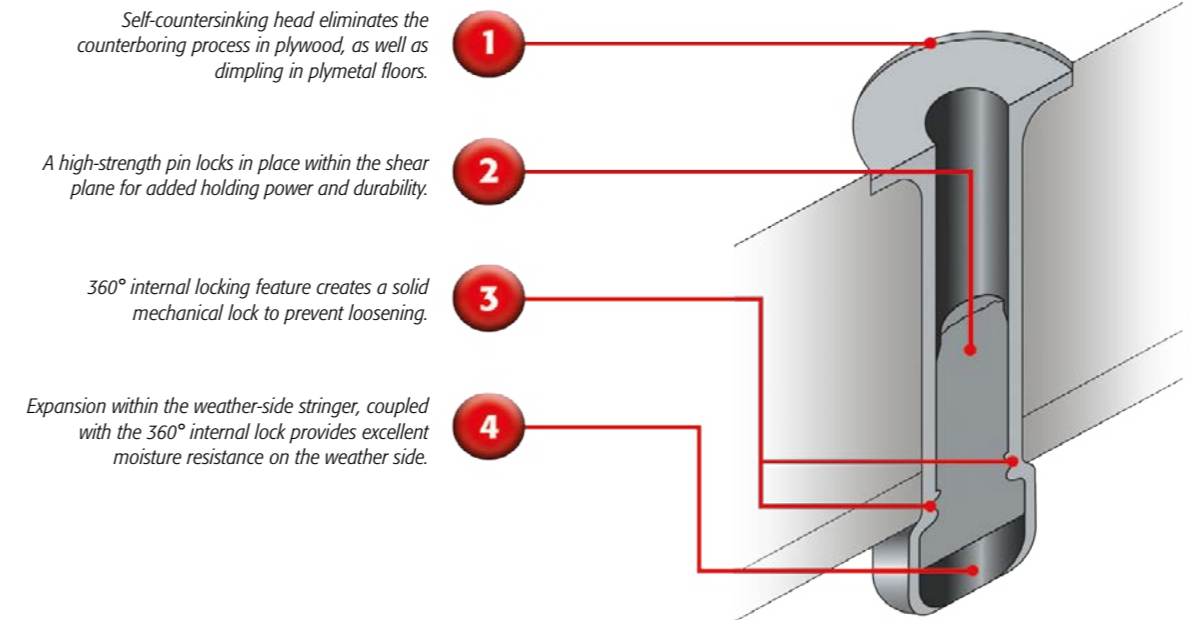

### Installation Sequence

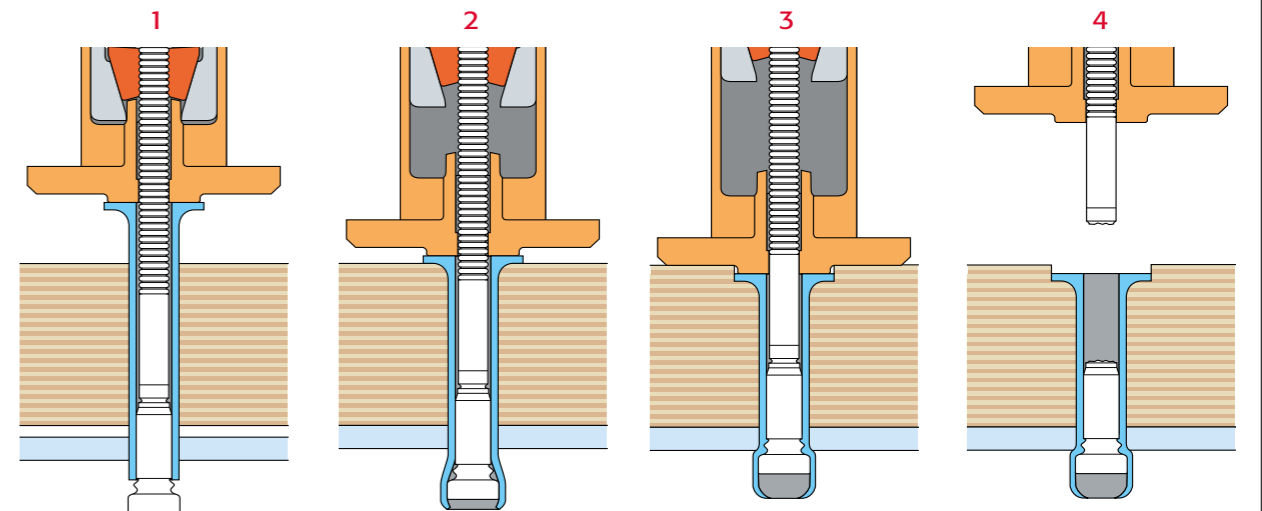

In fact they can be used in any industry where a quality, strong and dependable fastener is a required... application possibilities are endless!

Star Fasteners is also an accredited Huck tool service and repair department; expert technical knowledge and a large tool hire fleet complements the service. An important aspect of Star Fasteners quality promise is a

well-stocked tool room.

As a well-established leader in the global Huck fastener distribution network Star Fasteners are committed to supplying customers with the highest quality and most innovative fastener solutions on the market. Systems are ISO 9001:2015 approved, and accreditation from Alcumus SafeContractor has been achieved.

For more information about Star Fasteners unique value added services have a look on [starfasteners.co.uk](http://starfasteners.co.uk) or contact us on the following: -

Tel: +44 (0)115 9324939  
email: [sales@starfasteners.co.uk](mailto:sales@starfasteners.co.uk)  
[www.starfasteners.co.uk](http://www.starfasteners.co.uk)