



ARCONIC

Instruction Manual

SF46

BobTail® Hydraulic Installation Tool

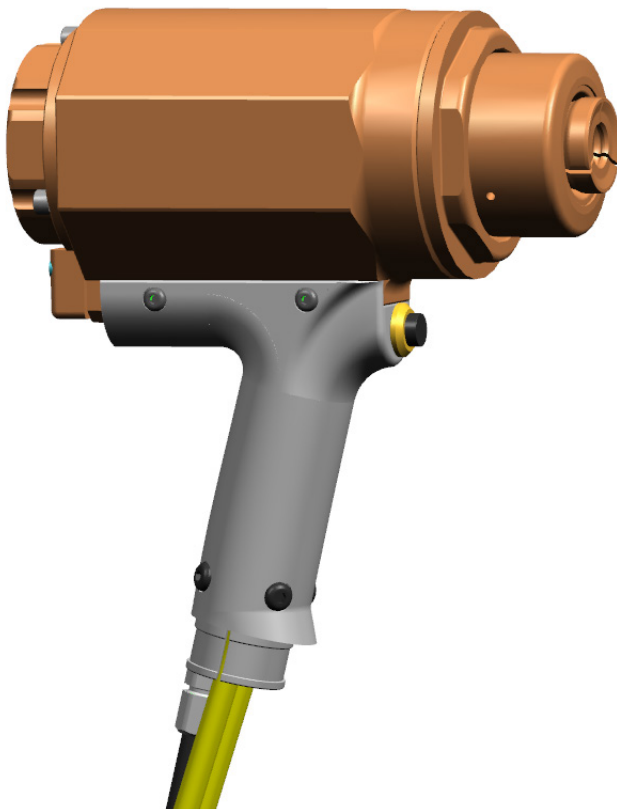

HUCK IS FOREVER.™

December 14, 2016

HK1181

Declaration of Conformity
2

Safety Instructions
3-4

Sticker Locations
4

Specifications
5

Principle of Operation
6

Preparation for Use
6

Tool-to-Powerig® Setup
7

Pressure Settings
7

**Assembly of NPTF
Threaded Components**
8

Operating Instructions
8

Optional Equipment
8

Maintenance
9

Components Drawing
10

Disassembly Instructions
11

Assembly Instructions
12

Makers of Huck®, Marson®, Recoil®
Brand Fasteners, Tools & Accessories



ARCONIC

EC Declaration of Conformity

Manufacturer:

Huck International, LLC, Industrial Products Group, 1 Corporate Drive, Kingston, NY, 12401, USA

Description of Machinery:

Models SF## families of hydraulic installation tools and specials based on their design (e.g. PR#####).

Relevant provisions complied with:

Council Directive related to Machinery (2006/42/EC)

British Standard related to hand held, non-electric power tools (ISO 11148-1:2011)

European Representative:

Rob Pattenden, Huck International, Ltd. Unit C Stafford Park 7, Telford Shropshire TF3 3BQ, England, United Kingdom

Authorized Signature/date:

I, the undersigned, do hereby declare that the equipment specified above conforms to the above Directive(s) and Standard(s).

Signature: 

Full Name: Robert B. Wilcox

Position: Engineering Manager

Location: Huck International, LLC d/b/a Arconic Fastening Systems and Rings
Kingston, New York, USA

Date: 01/11/2016 (November 1, 2016)



Declared dual number noise emission values in accordance with ISO 4871

A weighted sound power level, LWA: **76** dB (reference 1 pW) Uncertainty, KWA: 3 dB

A weighted emission sound pressure level at the work station, LpA: **65** dB (reference 20 µPa) Uncertainty, KpA: 3 dB

C-weighted peak emission sound pressure level, LpC, peak: **94** dB (reference 20 µPa) Uncertainty, KpC: 3 dB

Values determined according to noise test code ISO 3744. The sum of a measured noise emission value and its associated uncertainty represents an upper boundary of the range of values which is likely to occur in measurements.

Declared vibration emission values in accordance with EN 12096

Measured Vibrations emission value, a:	.56 m/s ²
Uncertainty, K:	.31 m/s ²
Values measured and determined according to ISO 28662-1, ISO 5349-2, and EN 1033	

Test data to support the above information is on file at:
Arconic Fastening Systems and Rings, Kingston Operations, Kingston, NY, USA.



Safety Instructions

GLOSSARY OF TERMS AND SYMBOLS:



- Product complies with requirements set forth by the relevant European directives.



- **READ MANUAL** prior to using this equipment.



- **EYE PROTECTION IS REQUIRED** while using this equipment.



- **HEARING PROTECTION IS REQUIRED** while using this equipment.



WARNINGS: Must be understood to avoid severe personal injury.



CAUTIONS: show conditions that will damage equipment and or structure.

Notes: are reminders of required procedures.

Bold, Italic type and underlining: emphasizes a specific instruction.

I. GENERAL SAFETY RULES:

1. A half hour long hands-on training session with qualified personnel is recommended before using Huck equipment.
2. Huck equipment must be maintained in a safe working condition at all times. Tools and hoses should be inspected at the beginning of each shift/day for damage or wear. Any repair should be done by a qualified repairman trained on Huck procedures.
3. For multiple hazards, read and understand the safety instructions before installing, operating, repairing, maintaining, changing accessories on, or working near the assembly power tool. Failure to do so can result in serious bodily injury.
4. Only qualified and trained operators should install, adjust or use the assembly power tool.
5. Do not modify this assembly power tool. This can reduce effectiveness of safety measures and increase operator risk.
6. Do not discard safety instructions; give them to the operator.
7. Do not use assembly power tool if it has been damaged.
8. Tools shall be inspected periodically to verify all ratings and markings required, and listed in the manual, are legibly marked on the tool. The employer/operator shall contact the manufacturer to obtain replacement marking labels when necessary. Refer to assembly drawing and parts list for replacement.
9. Tool is only to be used as stated in this manual. Any other use is prohibited.
10. Read MSDS Specifications before servicing the tool. MSDS specifications are available from the product manufacturer or your Huck representative.
11. Only genuine Huck parts shall be used for replacements or spares. Use of any other parts can result in tooling damage or personal injury.
12. Never remove any safety guards or pintail deflectors.
13. Never install a fastener in free air. Personal injury from fastener ejecting may occur.
14. Where applicable, always clear spent pintail out of nose

assembly before installing the next fastener.

15. Check clearance between trigger and work piece to ensure there is no pinch point when tool is activated. Remote triggers are available for hydraulic tooling if pinch point is unavoidable.
16. Do not abuse tool by dropping or using it as a hammer. Never use hydraulic or air lines as a handle or to bend or pry the tool. Reasonable care of installation tools by operators is an important factor in maintaining tool efficiency, eliminating downtime, and preventing an accident which may cause severe personal injury.
17. Never place hands between nose assembly and work piece. Keep hands clear from front of tool.
18. Tools with ejector rods should never be cycled with out nose assembly installed.
19. When two piece lock bolts are being used always make sure the collar orientation is correct. See fastener data sheet for correct positioning.

II. PROJECTILE HAZARDS:

1. Risk of whipping compressed air hose if tool is pneudraulic or pneumatic.
2. Disconnect the assembly power tool from energy source when changing inserted tools or accessories.
3. Be aware that failure of the workpiece, accessories, or the inserted tool itself can generate high velocity projectiles.
4. Always wear impact resistant eye protection during tool operation. The grade of protection required should be assessed for each use.
5. The risk of others should also be assessed at this time.
6. Ensure that the workpiece is securely fixed.
7. Check that the means of protection from ejection of fastener or pintail is in place and operative.
8. There is possibility of forcible ejection of pintails or spent mandrels from front of tool.

III. OPERATING HAZARDS:

1. Use of tool can expose the operator's hands to hazards including: crushing, impacts, cuts, abrasions and heat. Wear suitable gloves to protect hands.
2. Operators and maintenance personnel shall be physically able to handle the bulk, weight and power of the tool.
3. Hold the tool correctly and be ready to counteract normal or sudden movements with both hands available.
4. Maintain a balanced body position and secure footing.
5. Release trigger or stop start device in case of interruption of energy supply.
6. Use only fluids and lubricants recommended by the manufacturer.
7. Avoid unsuitable postures, as it is likely for these not to allow counteracting of normal or unexpected tool movement.
8. If the assembly power tool is fixed to a suspension device, make sure that fixation is secure.
9. Beware of the risk of crushing or pinching if nose equipment is not fitted.

Continued on next page...



Safety Instructions *(continued)*

IV. REPETITIVE MOTION HAZARDS:

1. When using assembly power tool, the operator can experience discomfort in the hands, arms, shoulders, neck or other parts of the body.
2. When using tool, the operator should adopt a comfortable posture while maintaining a secure footing and avoid awkward or off balanced postures.
3. The operator should change posture during extended tasks to help avoid discomfort and fatigue.
4. If the operator experiences symptoms such as persistent or recurring discomfort, pain, throbbing, aching, tingling, numbness, burning sensations or stiffness, these warnings should not be ignored. The operator should tell the employer and consult a qualified health professional.

V. ACCESSORIES HAZARDS:

1. Disconnect tool from energy supply before changing inserted tool or accessory.
2. Use only sizes and types of accessories and consumables that are recommended. Do not use other types or sizes of accessories or consumables.

VI. WORKPLACE HAZARDS:

1. Be aware of slippery surfaces caused by use of the tool and of trip hazards caused by the air line or hydraulic hose.
2. Proceed with caution while in unfamiliar surroundings; there could be hidden hazards such as electricity or other utility lines.
3. The assembly power tool is not intended for use in potentially explosive environments.
4. Tool is not insulated against contact with electrical power.
5. Ensure there are no electrical cables, gas pipes, etc., which can cause a hazard if damaged by use of the tool.

VII. NOISE HAZARDS:

1. Exposure to high noise levels can cause permanent, disabling hearing loss and other problems such as tinnitus, therefore risk assessment and the implementation of proper controls is essential.
2. Appropriate controls to reduce the risk may include actions such as damping materials to prevent workpiece from 'ringing'.
3. Use hearing protection in accordance with employer's instructions and as required by occupational health and safety regulations.
4. Operate and maintain tool as recommended in the instruction handbook to prevent an unnecessary increase in the noise level.
5. Select, maintain and replace the consumable / inserted tool as recommended to prevent an unnecessary increase in noise.
6. If the power tool has a silencer, always ensure that it is in place and in good working order when the tool is being operated.

VIII. VIBRATION HAZARDS:

1. Exposure to vibration can cause disabling damage to the

nerves and blood supply to the hands and arms.

2. Wear warm clothing when working in cold conditions and keep hands warm and dry.
3. If numbness, tingling, pain or whitening of the skin in the fingers or hands, stop using the tool, tell your employer and consult a physician.
4. Support the weight of the tool in a stand, tensioner or balancer in order to have a lighter grip on the tool.

X. HYDRAULIC TOOL SAFETY INSTRUCTIONS:



WARNINGS:

Do not exceed the maximum PULL or RETURN settings on tool.

Be sure all hose connections are tight. All tool hoses must be connected.

1. Carry out a daily check for damaged or worn hoses or hydraulic connections and replace if necessary.
2. Wipe all couplers clean before connecting. Failure to do so can result in damage to the quick couplers and cause overheating.
3. Ensure that couplings are clean and correctly engaged before operation.
4. Use only clean oil and filling equipment.
5. Power units require a free flow of air for cooling purposes and should therefore be positioned in a well ventilated area free from hazardous fumes.
6. Do not inspect or clean the tool while the hydraulic power source is connected. Accidental engagement of the tool can cause serious injury.
7. Be sure all hose connections are tight.
8. Wipe all couplers clean before connecting. Failure to do so can result in damage to the quick couplers and cause overheating.

Sticker Locations

This tool comes labeled with important stickers that contain safety and pressure settings information. It is necessary that these stickers remain on the tools and are easily read. If stickers become damaged or worn, or if they have been removed from the tool, they must be replaced. The part numbers are shown in the tool assembly drawing of this manual.



Specifications

Power Source: Huck POWERIG Hydraulic Unit

Hose Kits: Use only genuine HUCK Hose Kits rated at 10,000 psi working pressure.

Hydraulic Fluid: Hydraulic fluid shall meet DEXRON III, DEXRON VI, MERCON, Allison C-4 or equivalent ATF specifications.

Fire resistant fluid may be used if it is an ester based fluid such as Quintolubric HFD or equivalent. Water based fluid shall NOT be used as serious damage to equipment will occur.

Max Operating Temp: 125 ° F (51.7 ° C)

Max Flow Rate: 2 gpm (7.57 l/m)

Max Inlet Pull Pressure: 8000 psi, (552 bar)

Max Inlet Return Pressure: 7000 psi, (483 bar)

Pull Capacity: 49,600 lbf (220.6 kN)

Return Capacity: 24,900 lbf (110.8 kN)

Stroke: 2.50 inches (6.35 cm)

Weight: Approximately 17.8 lbs (8.07 kg)

DEXRON is a registered trademark of General Motors Corporation.

DIMENSION	A	B	C	Ø D	Ø E	F	G
Inches (cm)	7.33 (18.62)	6.95 (17.65)	4.00 (10.16)	4.00 (10.16)	3.50 (8.89)	2.02 (5.13)	3.00 (7.62)

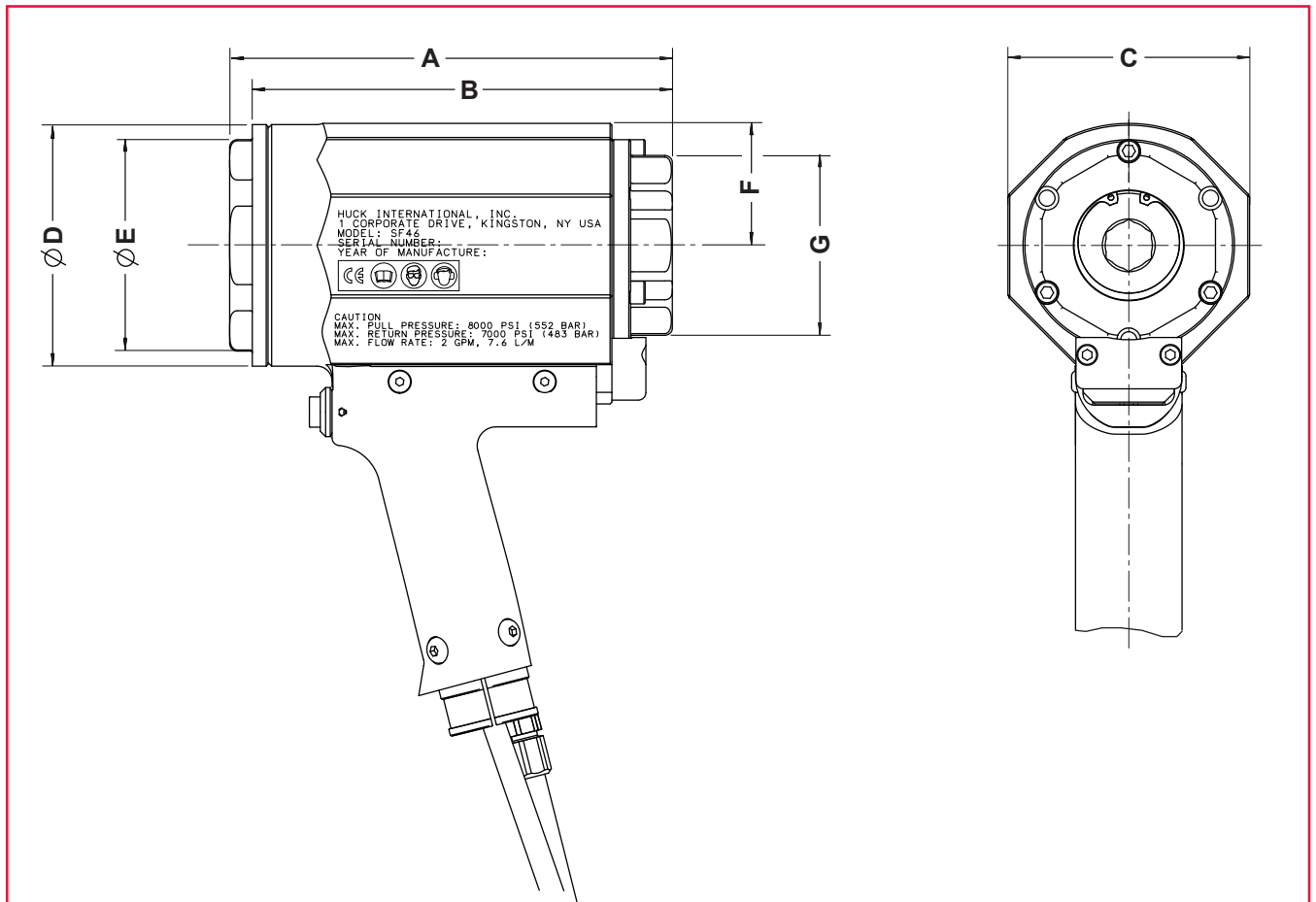



Principle of Operation

The operator pushes the tool with attached nose assembly over the end of the fastener until the tool puller bottoms on the fastener. When the trigger is pressed, the powerig receives a signal to swage the fastener. The piston moves forward to

start the swaging process. After the fastener is fully swaged, the operator must release the trigger, at which point the nose assembly anvil is ejected off of the collar and the tool is released from the fastener.

Preparation for Use



WARNINGS:

Read entire manual before using tool. A 30-minute training session with qualified personnel is recommended before using Huck equipment. When operating Huck equipment, always wear approved eye and hearing protection. Be sure there is adequate clearance for the operator's hands before proceeding. Connect the tool's hydraulic hoses to the POWERIG® Hydraulic Unit before connecting the tool's switch control cord to it. If not connected in this order, severe personal injury may occur. Correct PULL and RETURN pressures are required for operator safety and proper tool function. Huck Pressure Gauge P/N T-124883CE is available, and should be used as indicated in its instruction manual. Improper pressure settings may result in severe personal injury. Huck recommends that only Huck Powerig Hydraulic Units be used as a power source for Huck installation equipment. Hydraulic power units that deliver high pressure for both PULL and RETURN, AND ARE NOT EQUIPPED WITH RELIEF VALVES ARE SPECIFICALLY NOT RECOMMENDED AND MAY BE DANGEROUS.



CAUTIONS:

Keep disconnected hoses, couplers, and hydraulic fluid away from dirty surfaces and free of foreign matter. Contaminated fluid can cause valve failures in toll and Powerig.

Do not use TEFLON®* tape on pipe threads. Pipe threads may cause tape to shred resulting in tool malfunction. Apply Parker Threadmate®, Loctite® 567, or Slic-Tite® to male pipe threads per manufacturer's instructions. Hose couplers must be securely attached to ensure that the ball checks in the nipple and the body are completely open. Improperly assembled couplers will cause overheating and malfunctions in the tool and Powerig. Hand tighten couplers; do NOT use a pipe wrench.

4. First, turn hydraulic unit to OFF. Then disconnect power supply from hydraulic unit. Disconnect trigger control system from hydraulic unit.
5. Connect PULL pressure hose, with coupler nipple, into port "P" of tool. Use only with HUCK supplied hoses rated at 10,000 psi or greater. Check trigger assembly for apparent damage or wear. If required, adjust position of trigger assembly on hose. Connect trigger control system to hydraulic unit.
6. Connect hydraulic unit to power supply (air or electric). Turn hydraulic unit to ON. Depress trigger a few times to cycle tool and to circulate hydraulic fluid. Observe action of Tool and check for leaks.

Threadmate is a registered trademark of Parker Intangibles LLC.
TEFLON is a registered trademark of E. I. du Pont de Nemours and Company

POWER SOURCE CONNECTIONS

1. Coat hose fitting threads with a non-hardening TEFLON® thread compound such as Threadmate™, available from Huck in a 4oz. tube as p/n 508517.
2. Attach proper Nose Components to Tool as applicable.
3. Use Huck Powerig® Hydraulic Unit, or equivalent, that has been prepared for operation per instruction manual. Check PULL and RETURN pressures and, if required, adjust to pressures given in PRESSURE SETTINGS section of this manual.

Hydraulic Couplings

O-ring (P/N 504438) Back-up ring (P/N 501102)

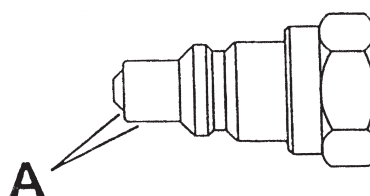
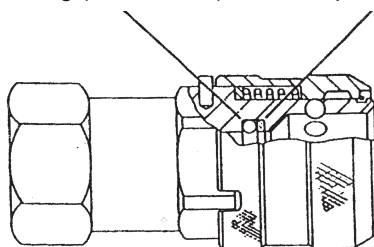

TIP: Use a fine India stone to remove nicks and burrs from diameter A and leading edge to prevent damage to O-ring.



Tool to Powerig Setup



WARNING: To prevent tripping hazard, suspend tools and route hoses off of floors.



WARNING: Only use compatible equipment with this tool.

1. Set Pull and Return pressures on Powerig using Huck Gage P/N: T-124833CE and **Table 1**.
2. First connect the Hydraulic Hoses to the Powerig.
3. Connect the other end of the Hose Assembly to the installation tool.
4. Connect the Power Cord from the Tool to the Hose Assembly.
5. Connect the Power Cord from the Hose Assembly to the Powerig.
6. Once the system is set up, turn on Powerig and install test fastener. Check to be sure that the fastener is installed correctly. This can be checked by using the appropriate swage gauge.

Pressure Settings

Table 1

Fastener Size	Grade 5 Pull (psi)	Grade 5 Return (psi)	Grade 8 Pull (psi)	Grade 8 Return (psi)	Class 8.8 Pull (psi)	Class 8.8 Return (psi)	Class 10.9 Pull (psi)	Class 10.9 Return (psi)
-24 (3/4")	3400	2000	5200	2800	-	-	-	-
20mm	-	-	-	-	3400	2000	6400	2850
-28 (7/8")	4300	2900	-	-	-	-	-	-
-32 (1")	5500	3200	7400	4300	-	-	-	-

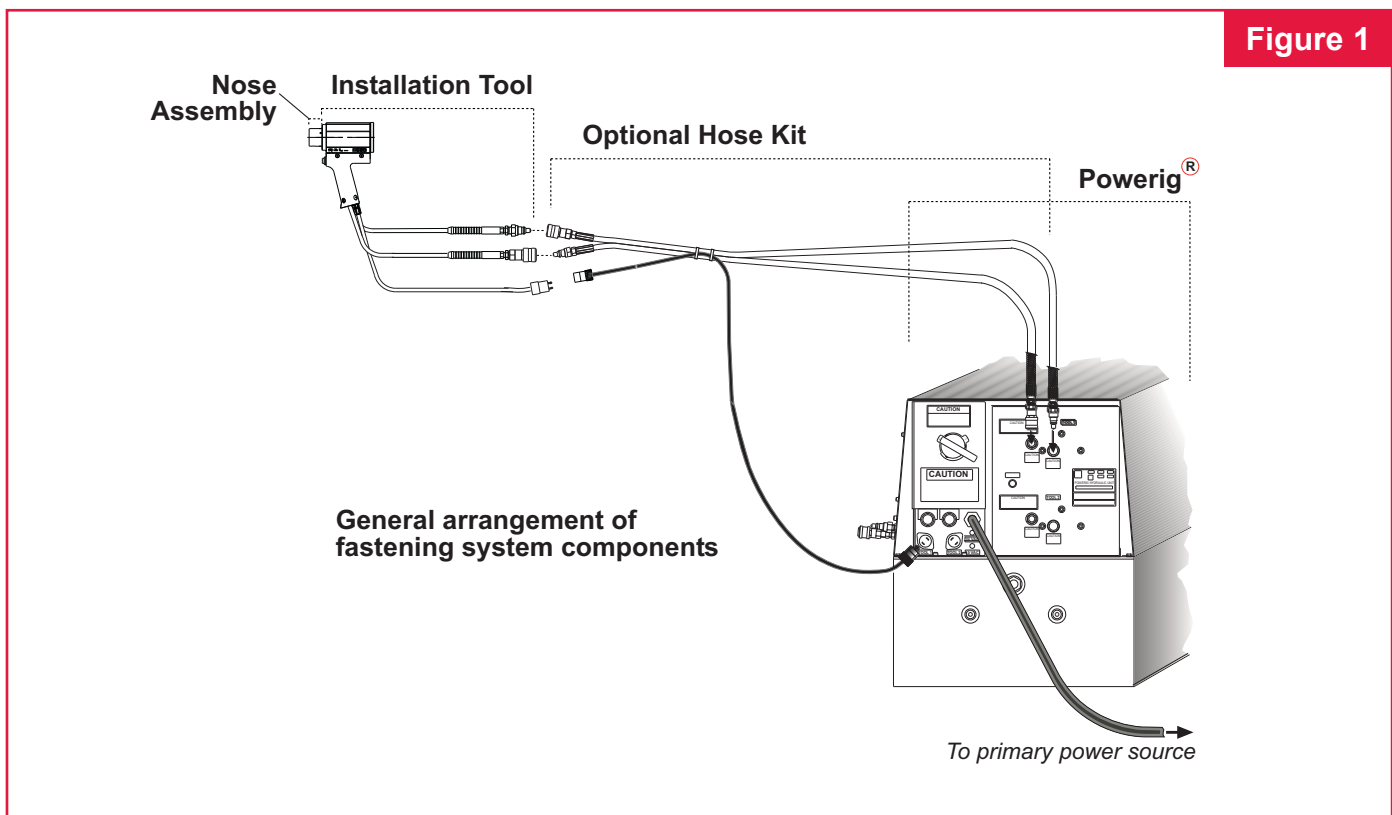



Assembly of NPTF Threaded Components

AIR FITTINGS

- 1) Apply TEFLON® stick to male threads which do not have pre-applied sealant per manufacturer's recommendations. (Proceed to All Fittings step 2)

HYDRAULIC FITTINGS

- 1) Apply Threadmate™ to male and female threads which do not have pre-applied sealant per manufacturer's recommendations. (Proceed to All Fittings step 2)

ALL FITTINGS:

- 2) Tighten to finger-tight condition.
- 3) Wrench tighten to 2-3 turns past finger-tight condition.
- 4) Final thread engagement can be checked (optional) by measuring the dimension from the flange of male fitting to the end of the thread before assembly and subtracting the distance under the flange after assembly.

Thread size	Final thread engagement at full make-up
1/8-27 NPTF	.235 inch (.59 cm)
1/4-18 NPTF	.339 inch (.86 cm)
3/8-18 NPTF	.351 inch (.89 cm)

Operating Instructions

For safe operation. Please read completely



WARNINGS:

To avoid severe personal injury: Wear approved eye and ear protection. Be sure of adequate clearance for Operator's hands before proceeding with fastener installation.

Do not pull on a pin without placing fastener/collar in a workpiece. This condition can cause pin to eject with great velocity and force if the pintail breaks off or teeth/grooves strip. This may cause severe personal injury.

To avoid pinch point, never place hand between nose assembly and work piece.

Only use compatible equipment with this tool.



CAUTION: Remove excess gap from between the sheets. This permits enough pintail to emerge from collar for ALL puller teeth to engage with pintail. If ALL teeth do not engage properly, jaws will be damaged.

GENERAL

Operators should receive training from qualified personnel. Do not bend tool to free if stuck. Tool should only be used to install fasteners. NEVER use as a jack/spreader or hammer.

TO INSTALL A BobTail® FASTENER:

1. Check work and remove excessive space between sheets. Gap is excessive if not enough pintail sticks through the collar for the nose assembly puller to grab onto).
2. Put BobTail pin in hole.
3. Slide BobTail collar over pin. (The flanged end of the collar must be towards the pieces being fastened.)
4. Push nose assembly onto the pin until the nose assembly puller stops against the pin. Tool and nose assembly must be held at right angles (90 degrees) to the work.
5. Depress tool trigger to start installation cycle.
6. When forward motion of nose assembly anvil stops, release trigger. Tool will go into its return stroke and push off the installed fastener.
7. The tool and nose assembly are ready for the next installation cycle.

Optional Equipment

TEFLON® Stick	-	503237
TEFLON® Sealant	-	620012
Loctite® 243	-	508567
Never-Seez® NS-160	-	505565
(anti-seize and lubricating compound)		
LUBRIPLATE® 130-AA	-	502723
Threadmate™ (4oz. tube)	-	508517
Pressure Gage	-	T-124833CE
Service Kit	-	SF46KIT
Swage Gage	-	HG-S-MBT20 (20mm)
		HG-S-BT24 (3/4")
Puller Wrench	-	128817
(Used to tighten and loosen nose assembly locknut)		

Hose Assembly	HOSE LENGTH	PART No.	
(Contains 2 identical	-	6 ft	118309-6
hydraulic hoses with	-	12 ft	118309-12
one male and one female	-	26 ft	118309-26
quick connect fitting at	-	38 ft	118309-38
each end)	-	52 ft	118309-52

Loctite is a registered trademark of Henkel Corporation, U.S.A..

Never-Seez is a registered trademark of Bostik, Inc.

LUBRIPLATE is a registered trademark of Fiske Brothers Refining Co.

Threadmate is a registered trademark of Parker Intangibles LLC..

TEFLON is a registered trademark of E. I. du Pont de Nemours and Company.



Maintenance



CAUTIONS:

- Consult MSDS before servicing tool.
- Keep dirt and other material out of hydraulic system.
- Separated parts must be kept away from dirty work surfaces.
- Dirt/debris in hydraulic fluid causes failure in Powerig® Hydraulic Unit valves.



WARNING: Inspect tool for damage or wear before each use. Do not operate if damaged or worn, as severe personal injury may occur.

- The efficiency and life of your tool depends on proper maintenance. Please read this section completely before proceeding with maintenance and repair. Use proper hand tools in a clean and well-lighted area. Only standard hand tools are required in most cases. Where a special tool is required, the description and part number are given.
- While clamping tool or parts in a vise, and when parts require force, use suitable soft materials to cushion impact. For example, using a half-inch brass drift, wood block and vise with soft jaws greatly reduces possibility of damaging tool. Remove components in a straight line without bending, cocking or undue force. Reassemble tool with the same care.

Sealants, Lubricants, Service Kits

- See **SPECIFICATIONS** for fluid type. Dispose of fluid in accordance with local environmental regulations. Recycle steel, aluminum, and plastic parts in accordance with local lawful and safe practices.
- Rub pipe plug threads and quick connect fittings with PTFE thread compound.



CAUTION: Do not use TEFLON®* tape on pipe threads. Pipe threads may cause tape to shred resulting in tool malfunction. (Threadmate™ is available from Huck in a 4oz. tube as part number 508517.)

- Smear LUBRIPLATE® 130AA*, or equivalent lubricant, on O-Rings and mating surfaces to aid assembly and to prevent damage to O-Rings. (LUBRIPLATE 130-AA is available in a tube as Huck P/N 502723.)
- Each Service Kit contains perishable parts for your specific tool. As foreseeable use may indicate, keep extra kits (O-rings, Back-up Rings, other standard items) and tool parts in stock. When stock is depleted, you can get kit items from any regular retailer of these items. See kit parts list for: O-ring size (AS568- number); material; durometer.

PREVENTIVE MAINTENANCE

System Inspection

Operating efficiency of the tool is directly related to the performance of the complete system, including the tool with nose assembly, hydraulic hoses, trigger and control cord, and POWERIG. Therefore, an effective preventive maintenance program includes scheduled inspections of the system to detect and correct minor troubles. At the beginning of each shift/day:

- Inspect tool and nose assembly for external damage.
- Verify that hydraulic hose fittings, couplings, and electrical connections are secure.
- Inspect hydraulic hoses for damage and deterioration. Do not use hoses to carry tool. Replace hoses if damaged.
- Observe tool, hoses, and hydraulic unit during operation to detect abnormal heating, leaks, or vibration.
- Max hydraulic fluid contamination level: NAS 1638 class 9, or ISO CODE 18/15, or SAE level 6.

Powerig Maintenance

Maintenance instructions and repair procedures are in the appropriate POWERIG Instruction Manual.

Tool Maintenance

Whenever disassembled and also at regular intervals (depending on severity and length of use), replace all seals, wipers, and back-up rings in tool. Service Kits, hoses, and extra parts should be kept in stock. Inspect cylinder bore, pistons, and piston rods for scored surfaces and excessive wear or damage. Replace as necessary.



CAUTION: Always replace seals, wipers, and back-up rings when tool is disassembled for any reason.

Nose Assembly Maintenance

Clean nose assembly often. Dip in mineral spirits or similar solvent to clean puller and wash away metal chips and debris. At regular intervals, as experience shows, disassemble nose and use a sharp "pick" to remove imbedded particles from grooves of puller.

* **DEXRON** is a registered trademark of General Motors Corp.
Quintolubric is a registered trademark of Quaker Chemical Corp.
Threadmate is a registered trademark of Parker Intangibles LLC.
TEFLON is a registered trademark of DuPont Corp.
LUBRIPLATE is a registered trademark of Fiske Brothers Refining Co.



Tool Components

Figure 4

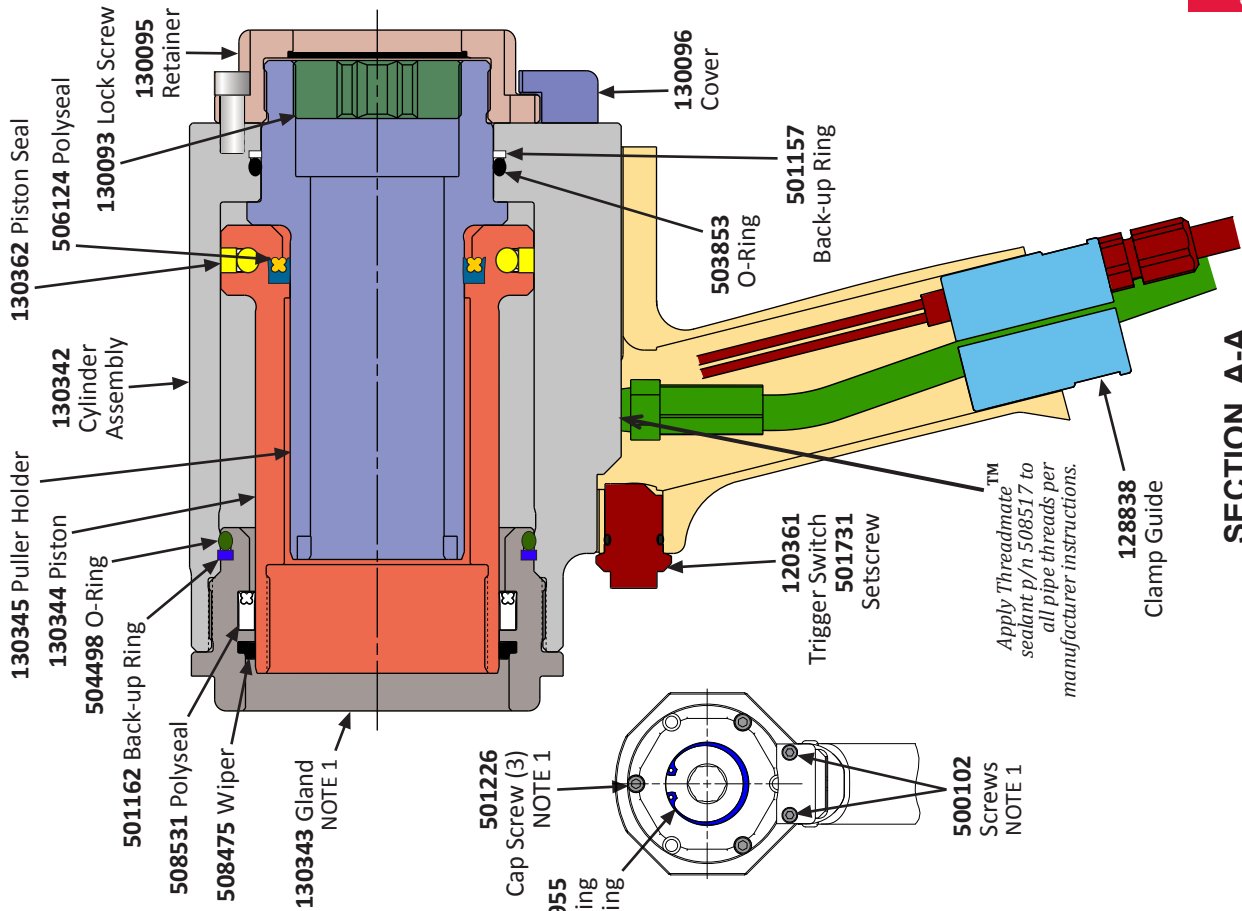

SECTION A-A

Apply Threadmate™ sealant p/n 508517 to all pipe threads per manufacturer instructions.

NOTES:

1. Apply Loctite 243® threadlocker p/n 508567 (or equivalent) to these threads per manufacturer's instructions.
2. WARNING Sticker and HUCK Trademark Sticker must be in place and readable at all times.

Threadmate™ is trademark of Parker Hannifin Corporation
 Loctite® is a registered trademark of Henkel Corporation, USA

590512-9 WARNING & CE Sticker NOTE 2
 590517 HUCK Trademark Sticker NOTE 2
 502483 Screw (4) NOTE 1

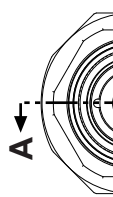



Disassembly



WARNING: Disconnect tool electrical control trigger system from Powerig® Hydraulic Unit BEFORE disconnecting tool hydraulic hoses from unit. If not disconnected in this order, severe personal injury may occur.

The following procedure is for complete disassembly. Disassemble only the components necessary to check damaged O-ring, wiper, back-up ring, piston seal, or other components.

1. Disconnect electrical control cord from powerig.
2. Uncouple tool's hydraulic hoses from powerig.
3. Remove nose assembly from tool (refer to **Nose ASSEMBLY REMOVAL** section below).
4. Using 3.25 inch wrench, unthread Gland fully and remove.
5. Pull piston out of cylinder assembly from front of tool.
6. Remove 2 capscrews and NPT plug cover.
7. Remove locking pin.
8. Push puller holder out of cylinder from back of tool.
9. Using a small diameter, dull-pointed rod, remove O-ring, back-up rings, wiper, piston seal, and polyseals.

Nose ASSEMBLY REMOVAL (Figure 5)

1. Turn anvil with wrench on flats or spanner wrench, as required. (RH thread)
2. Remove retaining ring from back of tool.
3. Pull anvil off.
4. Use 7/8 hex wrench to remove lockscrew from puller holder. (RH thread)
5. Remove cap screws, NPT plug cover and puller holder retainer.

6. a. **For installation noses and 3/4" and 20 mm cutter puller:**
Push the puller through the rear of the tool and out.
- b. **For cutter noses for 7/8" and larger, which will not fit through the puller holder:**
Push the puller rearward through the tool until the puller retainer is exposed. Unscrew (RH thread) and remove puller retainer. Then push puller out through the front of the tool.

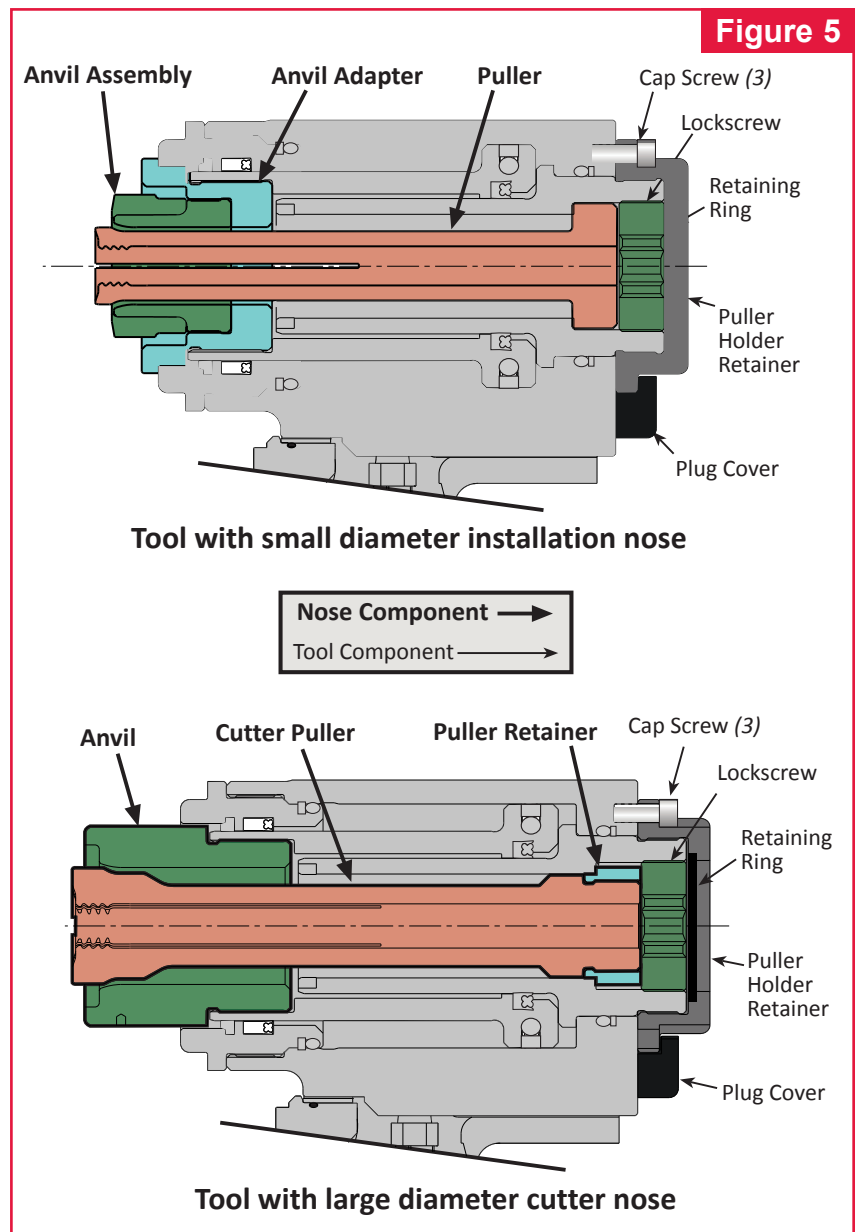



Assembly



WARNING: Do not omit any seals during servicing, leaks will result and personal injury may occur.



WARNING: Tool must be fully assembled with all components included.



CAUTION: Do not use TEFLON tape.

ASSEMBLY PREPARATION:

- (a) Clean components in mineral spirits or other solvent compatible with O-ring seals.
- (b) Clean out O-ring grooves.
- (c) Inspect components for scoring, excessive wear or damage.
- (d) Replace O-rings and back-up rings. Be sure that relative positions of the O-rings and back-up rings are as shown in assembly drawing.
- (e) Service Kit part number SF20KIT contains O-Rings, Back-up Rings and other seals necessary for servicing this tool.
- (f) Smear Lubriplate 130AA on O-rings and mating surfaces to prevent damage to O-rings and to aid assembly.

ASSEMBLY PROCEDURE (TOOL HEAD ONLY) (FIGURE 4):

1. Install O-ring and back-up ring in cylinder.
2. Install piston seal and polyseal on piston. Note orientation of polyseal.
3. Slide assembled piston over puller holder, and insert them into cylinder assembly.
4. Thread puller holder retainer on to puller holder, then back off until cap screw holes are aligned, and install 3 cap screws.
5. Install O-ring, back-up ring, wiper, and polyseal (note orientation of seals in Figure 4), on gland.

6. Apply Threadmate™ compound to threads of gland, and screw gland into cylinder.
Note: Threadmate is available from Huck in a 4oz. tube as part number 508517.
7. Connect tool hoses to powerig hoses.
8. Connect tool electrical trigger plug to powerig, and cycle tool a few times. Observe action of tool and check for leaks.
9. Disconnect tool electrical trigger plug, then tool hoses, from powerig.
10. Attach nose assembly to tool following instructions as described below.

ATTACHING NOSE ASSEMBLY (FIGURE 5):

Preparation: Remove retaining ring, cap screws, plug cover, lockscrew, and puller holder retainer.

1. Thread anvil into piston.
2. a. **For installation noses and 3/4" and 20 mm cutter puller:**
Slide puller in from rear of cylinder, through the anvil, until lip on back of piston is seated in the puller holder retainer.
- b. **For cutter noses for 7/8" and larger, which will not fit through the puller holder:**
Slide the piston through the anvil from the front of the tool and secure in place by screwing on the puller retainer.
3. Replace puller holder retainer, lockscrew, cap screws and retaining ring.

*Threadmate is a registered trademark of Parker Intangibles LLC.
Loctite is a registered trademark of Henkel Corporation, U.S.A.
LUBRIPLATE is a registered trademark of Fiske Brothers Refining Co.*



Limited Warranties

Limited Lifetime Warranty on BobTail® Tools:

Huck International, Inc. warrants to the original purchaser that its BobTail® installation tools manufactured after 12/1/2016 shall be free from defects in materials and workmanship for its **useful lifetime**. This warranty does not cover special order / non-standard products, or part failure due to normal wear, tool abuse or misapplication, or user non-compliance with the service requirements and conditions detailed in the product literature.

Two Year Limited Warranty on Installation Tools:

Huck International, Inc. warrants that its installation tools and Powerigs® manufactured after 12/1/2016 shall be free from defects in materials and workmanship for a period of two years from date of purchase by the end user. This warranty does not cover special order / non-standard products, or part failure due to normal wear, tool abuse or misapplication, or user non-compliance with the service requirements and conditions detailed in the product literature.

90 Day Limited Warranty on Nose Assemblies and Accessories:

Huck International, Inc. warrants that its nose assemblies and accessories shall be free from defects in materials and workmanship for a period of 90 days from date of purchase by the end user. This warranty does not cover special clearance noses, or special order / non-standard product, or part failure due to normal wear, abuse or misapplication, or user non-compliance with the service requirements and conditions detailed in the product literature.

Useful lifetime is defined as the period over which the product is expected to last physically, up to the point when replacement is required due to either normal in-service wear, or as part of a complete overhaul. Determination is made on a case-by case basis upon return of parts to Huck International, Inc. for evaluation.

Tooling, Part(s) and Other Items not manufactured by Huck:

HUCK makes no warranty with respect to the tooling, part(s), or other items manufactured by third parties. HUCK expressly disclaims any warranty expressed or implied, as to the condition, design, operation, merchantability, or fitness for use of any tool, part(s), or other items thereof not manufactured by HUCK. HUCK shall not be liable for any loss or damage, directly or indirectly, arising from the use of such tooling, part(s), or other items or breach of warranty or for any claim for incidental or consequential damages.

Huck shall not be liable for any loss or damage resulting from delays or non-fulfillment of orders owing to strikes, fires, accidents, transportation companies or for any reason or reasons beyond the control of the Huck or its suppliers.

Huck Installation Equipment:

Huck International, Inc. reserves the right to make changes in specifications and design and to discontinue models without notice.

Huck Installation Equipment should be serviced by trained service technicians only.

Always give the serial number of the equipment when corresponding or ordering service parts.

Complete repair facilities are maintained by Huck International, Inc. Please contact one of the offices listed below.

Eastern

One Corporate Drive Kingston, New York 12401-0250
Telephone (845) 331-7300 FAX (845) 334-7333

Outside USA and Canada

Contact your nearest Huck International location (see reverse).

In addition to the above repair facilities, there are Authorized Tool Service Centers (ATSC's) located throughout the United States. These service centers offer repair services, spare parts, Service Parts Kits, Service Tool Kits and Nose Assemblies. Please contact your Huck Representative or the nearest Huck International location (see reverse) for the ATSC in your area.



ARCONIC
Innovation, engineered.

Arconic Inc. (NYSE: ARNC) creates breakthrough products that shape industries. Working in close partnership with our customers, we solve complex engineering challenges to transform the way we fly, drive, build and power.

Through the ingenuity of our people and cutting-edge advanced manufacturing, we deliver these products at a quality and efficiency that ensures customer success and shareholder value.

Arconic Fastening Systems and Rings world-wide locations:

AMERICAS

Kingston Operations

1 Corporate Drive
Kingston, NY 12401
800-278-4825
845-331-7300
FAX: 845-334-7333

Tucson Operations

3724 East Columbia
Tucson, AZ 85714
800-234-4825
520-747-9898
FAX: 520-748-2142

Carson Operations

900 Watson Center Rd.
Carson, CA 90745
800-421-1459
310-830-8200
FAX: 310-830-1436

Acuña Operations

Hidalgo #120
Parque Industrial Amistad
26220 Acuña Coahuila
Mexico
FAX: 525-515-1776
TELEX: 1173530 LUKSME

Waco Operations

PO Box 8117
8001 Imperial Drive
Waco, TX 76714-8117
800-388-4825
254-776-2000
FAX: 254-751-5259

Huck is Forever, For the Long Haul, The Future of Fastening Technology, The Future of Assembly Technology, The Future of Tooling Technology, and Tools of Productivity are service marks of Huck International. Huck provides technical assistance regarding the use and application of Huck fasteners and tooling.

NOTICE: The information contained in this publication is only for general guidance

with regard to properties of the products shown and/or the means for selecting such products, and is not intended to create any warranty, express, implied, or statutory; all warranties are contained only in Huck's written quotations, acknowledgments, and/or purchase orders. It is recommended that the user secure specific, up-to-date data and information regarding each application and/or use of such products.

EUROPE

Telford Operations

Unit C, Stafford Park 7
Telford, Shropshire
England TF3 3BQ
01952-290011
FAX: 0952-290459

Us Operations

BP4
Clos D'Asseville
95450 Us par Vigny
France
33-1-30-27-9500
FAX: 33-1-34-66-0600

FAR EAST

Melbourne Operations

11508 Centre Road
Clayton, Victoria
Australia 3168
03-764-5500
Toll Free: 008-335-030
FAX: 03-764-5510



HUCK IS FOREVER.™