

**ARCONIC**

**Instruction Manual**  
**SF32 and SF32L**  
Hydraulic Installation Tool



**HUCK IS FOREVER.**

November 9, 2016

**HK1180**



ARCONIC

## EC Declaration of Conformity

### Manufacturer:

Huck International, LLC, Industrial Products Group, 1 Corporate Drive, Kingston, NY, 12401, USA

### Description of Machinery:

Models SF### families of hydraulic installation tools and specials based on their design (e.g. PR#####).

### Relevant provisions complied with:

Council Directive related to Machinery (2006/42/EC)

British Standard related to hand held, non-electric power tools (ISO 11148-1:2011)

### European Representative:

Rob Pattenden, Huck International, Ltd. Unit C Stafford Park 7, Telford Shropshire TF3 3BQ, England, United Kingdom

### Authorized Signature/date:

I, the undersigned, do hereby declare that the equipment specified above conforms to the above Directive(s) and Standard(s).

Signature:

Full Name: Robert B. Wilcox

Position: Engineering Manager

Location: Huck International, LLC d/b/a Arconic Fastening Systems and Rings  
Kingston, New York, USA

Date: 01/11/2016 (November 1, 2016)



### Declared dual number noise emission values in accordance with ISO 4871

A weighted sound power level, LWA: **76** dB (reference 1 pW) Uncertainty, KWA: 3 dB

A weighted emission sound pressure level at the work station, LpA: **65** dB (reference 20 µPa) Uncertainty, KpA: 3 dB

C-weighted peak emission sound pressure level, LpC, peak: **94** dB (reference 20 µPa) Uncertainty, KpC: 3 dB

Values determined according to noise test code ISO 3744. The sum of a measured noise emission value and its associated uncertainty represents an upper boundary of the range of values which is likely to occur in measurements.

### Declared vibration emission values in accordance with EN 12096

Measured Vibrations emission value, a:	<b>.56</b> m/s <sup>2</sup>
Uncertainty, K:	<b>.31</b> m/s <sup>2</sup>
Values measured and determined according to ISO 28662-1, ISO 5349-2, and EN 1033	

Test data to support the above information is on file at:  
Arconic Fastening Systems and Rings, Kingston Operations, Kingston, NY, USA.



## CONTENTS

SAFETY 4-5	
SPECIFICATIONS . . . . .	6
PRINCIPLE OF OPERATION . . . . .	7
PREPARATION FOR USE . . . . .	7
TOOL TO POWERIG SET-UP . . . . .	8
PRESSURE SETTINGS . . . . .	8
ASSEMBLY OF NPTF THREADED COMPONENTS. . . . .	9
OPERATING INSTRUCTIONS. . . . .	9
MAINTENANCE . . . . .	10
HYDRAULIC COUPLINGS. . . . .	11
OPTIONAL EQUIPMENT . . . . .	11
STICKER LOCATIONS . . . . .	11
TOOL COMPONENTS DRAWING . . . . .	12
TOOL DISASSEMBLY . . . . .	13
TOOL ASSEMBLY . . . . .	14



# SAFETY INSTRUCTIONS

## GLOSSARY OF TERMS AND SYMBOLS:



- Product complies with requirements set forth by the relevant European directives.



- **READ MANUAL** prior to using this equipment.



- **EYE PROTECTION IS REQUIRED** while using this equipment.



- **HEARING PROTECTION IS REQUIRED** while using this equipment.



**WARNINGS: Must be understood to avoid severe personal injury.**



**CAUTIONS: show conditions that will damage equipment and or structure.**

**Notes:** are reminders of required procedures.

***Bold, Italic type and underlining:*** emphasizes a specific instruction.

## I. GENERAL SAFETY RULES:

1. A half hour long hands-on training session with qualified personnel is recommended before using Huck equipment.
2. Huck equipment must be maintained in a safe working condition at all times. Tools and hoses should be inspected at the beginning of each shift/day for damage or wear. Any repair should be done by a qualified repairman trained on Huck procedures.
3. For multiple hazards, read and understand the safety instructions before installing, operating, repairing, maintaining, changing accessories on, or working near the assembly power tool. Failure to do so can result in serious bodily injury.
4. Only qualified and trained operators should install, adjust or use the assembly power tool.
5. Do not modify this assembly power tool. This can reduce effectiveness of safety measures and increase operator risk.
6. Do not discard safety instructions; give them to the operator.
7. Do not use assembly power tool if it has been damaged.
8. Tools shall be inspected periodically to verify all ratings and markings required, and listed in the manual, are legibly marked on the tool. The employer/operator shall contact the manufacturer to obtain replacement marking labels when necessary. Refer to assembly drawing and parts list for replacement.
9. Tool is only to be used as stated in this manual. Any other use is prohibited.
10. Read MSDS Specifications before servicing the tool. MSDS specifications are available from the product manufacturer or your Huck representative.
11. Only genuine Huck parts shall be used for replacements or spares. Use of any other parts can result in tooling damage or personal injury.
12. Never remove any safety guards or pintail deflectors.
13. Never install a fastener in free air. Personal injury from fastener ejecting may occur.

14. Where applicable, always clear spent pintail out of nose assembly before installing the next fastener.
15. Check clearance between trigger and work piece to ensure there is no pinch point when tool is activated. Remote triggers are available for hydraulic tooling if pinch point is unavoidable.
16. Do not abuse tool by dropping or using it as a hammer. Never use hydraulic or air lines as a handle or to bend or pry the tool. Reasonable care of installation tools by operators is an important factor in maintaining tool efficiency, eliminating downtime, and preventing an accident which may cause severe personal injury.
17. Never place hands between nose assembly and work piece. Keep hands clear from front of tool.
18. Tools with ejector rods should never be cycled with out nose assembly installed.
19. When two piece lock bolts are being used always make sure the collar orientation is correct. See fastener data sheet for correct positioning.

## II. PROJECTILE HAZARDS:

1. Risk of whipping compressed air hose if tool is pneudraulic or pneumatic.
2. Disconnect the assembly power tool from energy source when changing inserted tools or accessories.
3. Be aware that failure of the workpiece, accessories, or the inserted tool itself can generate high velocity projectiles.
4. Always wear impact resistant eye protection during tool operation. The grade of protection required should be assessed for each use.
5. The risk of others should also be assessed at this time.
6. Ensure that the workpiece is securely fixed.
7. Check that the means of protection from ejection of fastener or pintail is in place and operative.
8. There is possibility of forcible ejection of pintails or spent mandrels from front of tool.

## III. OPERATING HAZARDS:

1. Use of tool can expose the operator's hands to hazards including: crushing, impacts, cuts, abrasions and heat. Wear suitable gloves to protect hands.
2. Operators and maintenance personnel shall be physically able to handle the bulk, weight and power of the tool.
3. Hold the tool correctly and be ready to counteract normal or sudden movements with both hands available.
4. Maintain a balanced body position and secure footing.
5. Release trigger or stop start device in case of interruption of energy supply.
6. Use only fluids and lubricants recommended by the manufacturer.
7. Avoid unsuitable postures, as it is likely for these not to allow counteracting of normal or unexpected tool movement.
8. If the assembly power tool is fixed to a suspension device, make sure that fixation is secure.
9. Beware of the risk of crushing or pinching if nose equipment is not fitted.

*Continued on next page...*



## **SAFETY INSTRUCTIONS** (continued)

### **IV. REPETITIVE MOTION HAZARDS:**

1. When using assembly power tool, the operator can experience discomfort in the hands, arms, shoulders, neck or other parts of the body.
2. When using tool, the operator should adopt a comfortable posture while maintaining a secure footing and avoid awkward or off balanced postures.
3. The operator should change posture during extended tasks to help avoid discomfort and fatigue.
4. If the operator experiences symptoms such as persistent or recurring discomfort, pain, throbbing, aching, tingling, numbness, burning sensations or stiffness, these warnings should not be ignored. The operator should tell the employer and consult a qualified health professional.

### **V. ACCESSORIES HAZARDS:**

1. Disconnect tool from energy supply before changing inserted tool or accessory.
2. Use only sizes and types of accessories and consumables that are recommended. Do not use other types or sizes of accessories or consumables.

### **VI. WORKPLACE HAZARDS:**

1. Be aware of slippery surfaces caused by use of the tool and of trip hazards caused by the air line or hydraulic hose.
2. Proceed with caution while in unfamiliar surroundings; there could be hidden hazards such as electricity or other utility lines.
3. The assembly power tool is not intended for use in potentially explosive environments.
4. Tool is not insulated against contact with electrical power.
5. Ensure there are no electrical cables, gas pipes, etc., which can cause a hazard if damaged by use of the tool.
6. Where deemed appropriate, parts are plated, black oxide treated, anodized, etc. to minimize wear and corrosion. This treatment does not guarantee that parts will not wear and/or corrode since these conditions are based on individual customer use and environment.

### **VII. NOISE HAZARDS:**

1. Exposure to high noise levels can cause permanent, disabling hearing loss and other problems such as tinnitus, therefore risk assessment and the implementation of proper controls is essential.
2. Appropriate controls to reduce the risk may include actions such as damping materials to prevent workpiece from 'ringing'.
3. Use hearing protection in accordance with employer's instructions and as required by occupational health and safety regulations.
4. Operate and maintain tool as recommended in the instruction handbook to prevent an unnecessary increase in the noise level.
5. Select, maintain and replace the consumable / inserted tool as recommended to prevent an unnecessary increase in noise.

6. If the power tool has a silencer, always ensure that it is in place and in good working order when the tool is being operated.

### **VIII. VIBRATION HAZARDS:**

1. Exposure to vibration can cause disabling damage to the nerves and blood supply to the hands and arms.
2. Wear warm clothing when working in cold conditions and keep hands warm and dry.
3. If numbness, tingling, pain or whitening of the skin in the fingers or hands, stop using the tool, tell your employer and consult a physician.
4. Support the weight of the tool in a stand, tensioner or balancer in order to have a lighter grip on the tool.

### **X. HYDRAULIC TOOL SAFETY INSTRUCTIONS:**



**WARNING: Do not exceed maximum pull or return settings on tool.**

1. Carry out a daily check for damaged or worn hoses or hydraulic connections and replace if necessary.
2. Wipe all couplers clean before connecting. Failure to do so can result in damage to the quick couplers and cause overheating.
3. Ensure that couplings are clean and correctly engaged before operation.



**WARNING: Be sure all hose connections are tight. All tool hoses must be connected.**

4. Use only clean oil and filling equipment.
5. Power units require a free flow of air for cooling purposes and should therefore be positioned in a well ventilated area free from hazardous fumes.
6. Do not inspect or clean the tool while the hydraulic power source is connected. Accidental engagement of the tool can cause serious injury.
7. Be sure all hose connections are tight.
8. Wipe all couplers clean before connecting. Failure to do so can result in damage to the quick couplers and cause overheating.



## SPECIFICATIONS

**Power Source:** Huck Powerig® Hydraulic Unit

**Hose Kits:** Use only genuine HUCK Hose Kits rated at 10,000 psi working pressure.

**Hydraulic Fluid:** Hydraulic fluid shall meet DEXRON® III, DEXRON VI, MERCON, Allison C-4 or equivalent ATF specifications.

Fire resistant fluid may be used if it is an ester based fluid such as Quintolubric HFD or equivalent. Water based fluid shall NOT be used as serious damage to equipment will occur.

**Max Operating Temp:** 125 °F (51.7 °C)

**Max Flow Rate:** 2 gpm (7.57 l/m)

**Max Inlet Pull Pressure:** 8000 psi (550 bar)

**Max Inlet Return Pressure:** 7000 psi (483 bar)

**Pull Capacity:** 33,100 lbf (147.2 kN)

**Return Capacity:** 18,700 lbf (83.2 kN)

**Stroke:** 2.00 inches (5.08 cm)

**Weight:** Approximately 14.5 lbs (6.58 kg)

*DEXRON is a registered trademark of General Motors Corporation.*

DIMENSION	A	B	C	D	E	F	G
Inches (cm)	5.58 (14.2)	5.22 (13.3)	4.66 (11.8)	3.40 (8.6)	3.00 (7.6)	1.70 (4.3)	3.40 (8.6)

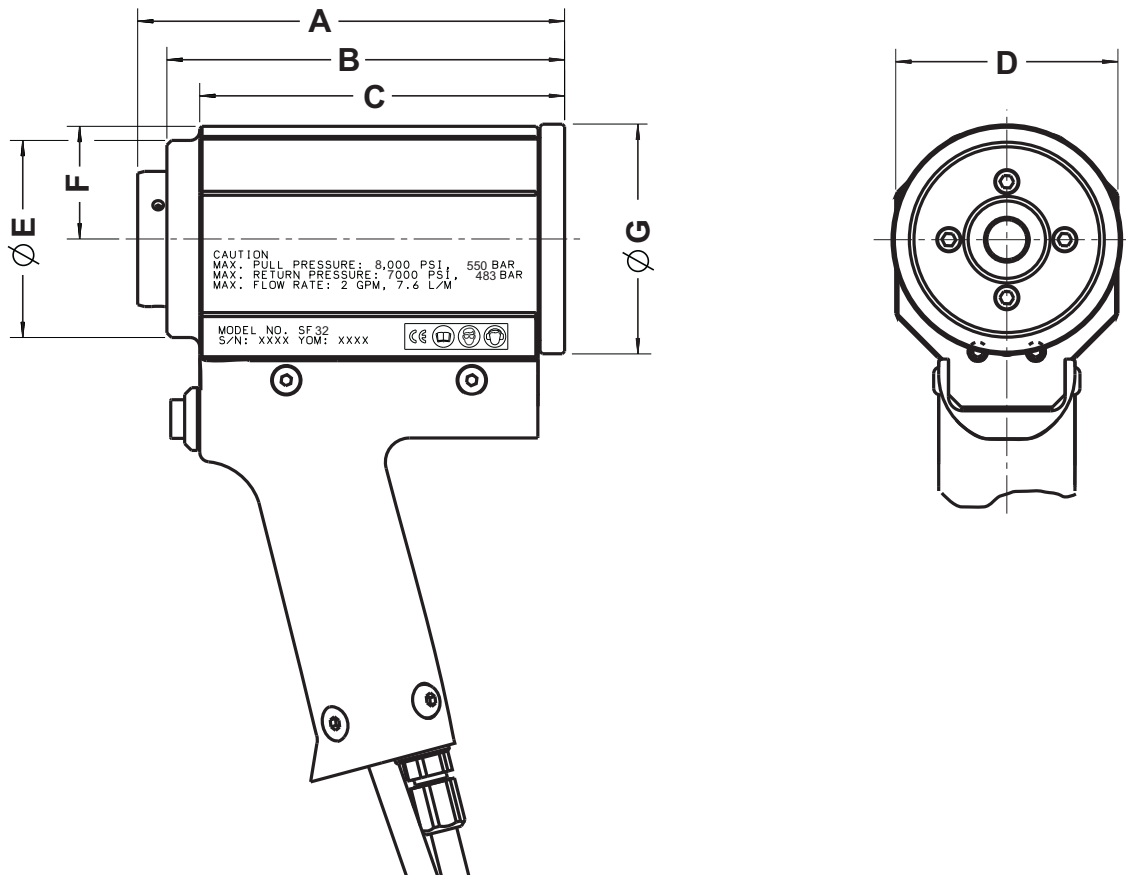



## PRINCIPLE OF OPERATION

The operator pushes the tool with attached nose assembly over the end of the fastener until the tool puller bottoms on the fastener. When the trigger is pressed, the Powerig® receives a signal to swage the fastener. The piston moves forward to start the swaging process.

After the fastener is fully swaged, the operator must release the trigger, at which point the nose assembly anvil is ejected off of the collar and the tool is released from the fastener.

## PREPARATION FOR USE



### WARNINGS:

Read full manual before using tool.

A half-hour training session with qualified personnel is recommended before using Huck equipment.

When operating Huck installation equipment, always wear approved eye protection.

Be sure there is adequate clearance for the operator's hands before proceeding.

Correct PULL and RETURN pressures are required for operator safety and for tool function. Gauge T-124833CE is available for checking pressures. See **PRESSURE SETTINGS** and Gauge Instruction Manual. Failure to verify pressures may result in severe personal injury.

Connect tool's hydraulic hoses to Powerig Hydraulic Unit before connecting tool's switch control cord to unit. If not connected in this order, severe personal injury may occur.

Huck recommends that only Huck Powerig Hydraulic Units be used as a power source for Huck installation equipment. Hydraulic power units that deliver high pressure for both PULL and RETURN, **AND ARE NOT EQUIPPED WITH RELIEF VALVES ARE SPECIFICALLY NOT RECOMMENDED AND MAY BE DANGEROUS.**



### CAUTIONS:

Do not use TEFLON® tape on pipe threads. Pipe threads may cause tape to shred resulting in tool malfunction. (Threadmate™ is available from Huck in a 4oz. tube as part number 508517.)

Do not let disconnected hoses and couplers contact a dirty floor. Keep harmful material out of hydraulic fluid. Dirt in hydraulic fluid causes valve failure In Tool and In Powerig Hydraulic Unit.

Hose couplers must be completely joined together to insure that ball checks in both nipple and body are completely open. Improperly assembled couplers will cause overheating and malfunctions in both tool and Powerig. Hand tighten couplers. Do NOT use a pipe wrench.

### POWER SOURCE CONNECTIONS

1. Coat hose fitting threads with a non-hardening TEFLON® thread compound such as Threadmate™, available from Huck in a 4oz. tube as p/n 508517.
2. Attach proper Nose Components to Tool as applicable.
3. Use Huck Powerig® Hydraulic Unit, or equivalent, that has been prepared for operation per instruction manual. Check PULL and RETURN pressures and, if required, adjust to pressures given in **PRESSURE SETTINGS** section of this manual.
4. First, turn hydraulic unit to OFF. Then disconnect power supply from hydraulic unit. Disconnect trigger control system from hydraulic unit.
5. Connect PULL pressure hose, with coupler nipple, into port "P" of tool. Use only with HUCK supplied hoses rated at 10,000 psi or greater. Check trigger assembly for apparent damage or wear. If required, adjust position of trigger assembly on hose. Connect trigger control system to hydraulic unit.
6. Connect hydraulic unit to power supply (air or electric). Turn hydraulic unit to ON. Depress trigger a few times to cycle tool and to circulate hydraulic fluid. Observe action of Tool and check for leaks.



## TOOL TO POWERIG SETUP



### WARNINGS:

To prevent tripping hazard, suspend tools and route hoses off of floors.

Only use compatible equipment with this tool.

1. Set Pull and Return pressures on Powerig using Huck Gage P/N: T-124833CE and **Table 1**.
2. First connect the Hydraulic Hoses to the Powerig.
3. Connect the other end of the Hose Assembly to the installation tool.
4. Connect the Trigger/Control Cord from the Tool to the Hose Assembly.
5. Connect the Trigger/Control Cord from the Hose Assembly to the Powerig.
6. Once the system is set up, turn on Powerig and install test fastener. Check to be sure that the fastener is installed correctly. This can be checked by using the appropriate swage gauge.

## PRESSURE SETTINGS

**Table 1**

Fastener Size	Grade 5 Pull (psi)	Grade 5 Return (psi)	Grade 8 Pull (psi)	Grade 8 Return (psi)	Class 8.8 Pull (psi)	Class 8.8 Return (psi)	Class 10.9 Pull (psi)	Class 10.9 Return (psi)
-24 (3/4")	5100	2700	7700	3800	-	-	-	-
20mm	-	-	-	-	5100	2700	7700	3800

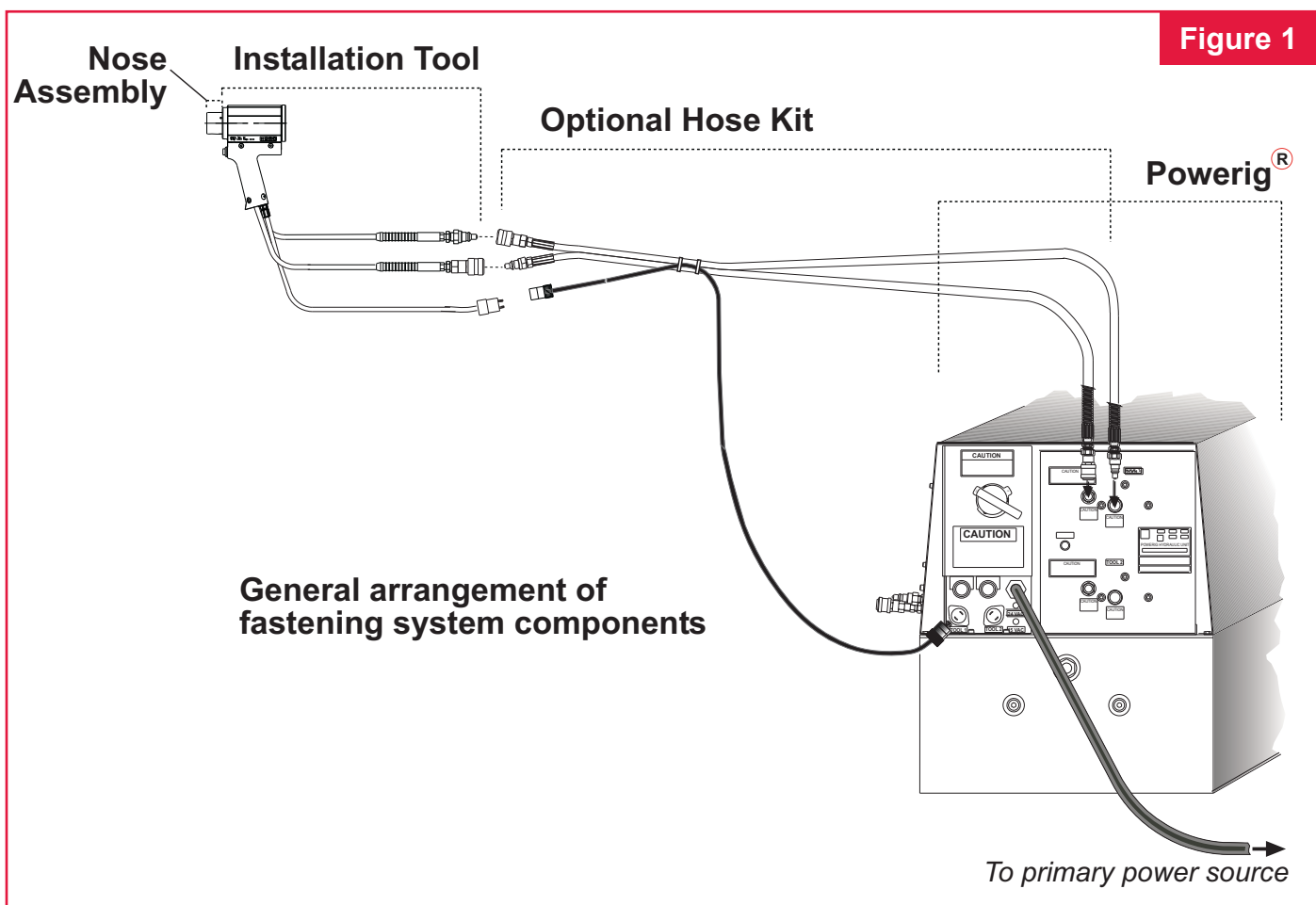





## ASSEMBLY OF NPTF THREADED COMPONENTS

### AIR FITTINGS

- 1) Apply TEFLON® stick to male threads which do not have pre-applied sealant per manufacturer's recommendations. (Proceed to All Fittings step 2)

### HYDRAULIC FITTINGS

- 1) Apply Threadmate™ to male and female threads which do not have pre-applied sealant per manufacturer's recommendations. (Proceed to All Fittings step 2)

### ALL FITTINGS:

- 2) Tighten to finger-tight condition.
- 3) Wrench tighten to 2-3 turns past finger-tight condition.
- 4) Final thread engagement can be checked (optional) by measuring the dimension from the flange of male fitting to the end of the thread before assembly and subtracting the distance under the flange after assembly. See Table 2.

**TABLE 2**

THREAD SIZE	FINAL THREAD ENGAGEMENT AT FULL MAKE-UP (inches)	NUMBER OF TURNS FROM FINGER-TIGHT CONDITION
1/8-27 NPTF	.235	2-3
1/4-18 NPTF	.339	2-3
3/8-18 NPTF	.351	2-3

## OPERATING INSTRUCTIONS

*For safe operation, read completely*



### WARNINGS:

To avoid severe personal injury: Wear approved eye and ear protection. Be sure of adequate clearance for Operator's hands before proceeding with fastener installation.

Do not pull on a pin without placing fastener/collar in a workpiece. This condition can cause pin to eject with great velocity and force if the pintail breaks off or teeth/grooves strip. This may cause severe personal injury.

To avoid pinch point, never place hand between nose assembly and work piece.

Only use compatible equipment with this tool.



**CAUTION:** Remove excess gap from between the workpiece sheets. This permits enough pintail to emerge from collar for ALL puller teeth to engage with pintail. **IF ALL TEETH DO NOT ENGAGE PROPERLY, PULLER WILL BE DAMAGED.**

### TO INSTALL A BobTail® FASTENER:

1. Check work and remove excessive gap. (Gap is the space between sheets. Gap is excessive if not enough pintail sticks through the collar for the nose assembly puller to grab onto).
2. Put BobTail fastener in the hole.
3. Slide BobTail collar over fastener. (The flanged end of the collar must be towards the pieces being fastened.)
4. With the tool and nose assembly at a right angle (90 degrees) to the workpiece, push the nose assembly completely onto the fastener until the nose assembly puller stops against the pin and all puller teeth are engaged. SEE CAUTION.
5. Depress tool trigger to start installation cycle.
6. When forward motion of nose assembly anvil stops, release trigger. Tool will go into its return stroke and push off the installed fastener.
7. The tool and nose assembly are ready for the next installation cycle.

### GENERAL

Operators should receive training from qualified personnel.

Do not bend tool to free if stuck.

Tool should only be used to install fasteners; NEVER use tool as a jack/spreader or hammer.



## MAINTENANCE

### PREVENTIVE MAINTENANCE



**CAUTIONS:**  
Consult MSDS before servicing tool.

Keep dirt and other material out of hydraulic system.

Separated parts must be kept away from dirty work surfaces.

Dirt/debris in hydraulic fluid causes failure in Powerig® Hydraulic Unit valves.



**WARNING:** Inspect tool for damage or wear before each use. Do not operate if damaged or worn, as severe personal injury may occur.

The efficiency and life of your tool depends on proper maintenance. Please read this section completely before proceeding with maintenance and repair. Use proper hand tools in a clean and well-lighted area. Only standard hand tools are required in most cases. Where a special tool is required, the description and part number are given.

While clamping tool or parts in a vise, and when parts require force, use suitable soft materials to cushion impact. For example, using a half-inch brass drift, wood block and vise with soft jaws greatly reduces possibility of damaging tool. Remove components in a straight line without bending, cocking or undue force. Reassemble tool with the same care.

### SEALANTS, LUBRICANTS, SERVICE KITS

- See **SPECIFICATIONS** for fluid type. Dispose of fluid in accordance with local environmental regulations. Recycle steel, aluminum, and plastic parts in accordance with local lawful and safe practices.
- Rub pipe plug threads and quick connect fittings with PTFE thread compound.



**CAUTION:** Do not use TEFLON®\* tape on pipe threads. Pipe threads may cause tape to shred resulting in tool malfunction. Apply Parker Threadmate, Loctite 567, or Slic-tite stick to male pipe threads per manufacturer's instructions.

- Smear LUBRIPLATE® 130AA\*, or equivalent lubricant, on O-Rings and mating surfaces to aid assembly and to prevent damage to O-Rings. (LUBRIPLATE 130-AA is available in a tube as Huck P/N 502723.)
- Each Service Kit contains perishable parts for your specific tool. As foreseeable use may indicate, keep extra kits (O-rings, Back-up Rings, other standard items) and tool parts in stock. When stock is depleted, you can get kit items from any regular retailer of these items. See kit parts list for: O-ring size (AS568- number); material; durometer.

### SYSTEM INSPECTION

Operating efficiency of the tool is directly related to the performance of the complete system, including the tool with nose assembly, hydraulic hoses, trigger and control cord, and POWERIG. Therefore, an effective preventive maintenance program includes scheduled inspections of the system to detect and correct minor troubles. At the beginning of each shift/day:

- Inspect tool and nose assembly for external damage.
- Verify that hydraulic hose fittings, couplings, and electrical connections are secure.
- Inspect hydraulic hoses for damage and deterioration. Do not use hoses to carry tool. Replace hoses if damaged.
- Observe tool, hoses, and hydraulic unit during operation to detect abnormal heating, leaks, or vibration.
- Max hydraulic fluid contamination level: NAS 1638 class 9, or ISO CODE 18/15, or SAE level 6.

### POWERIG MAINTENANCE

Maintenance instructions and repair procedures are in the appropriate Powerig Instruction Manual.



**CAUTION:** Always replace seals, wipers, and back-up rings when tool is disassembled for any reason.

### TOOL MAINTENANCE

Whenever disassembled and also at regular intervals (depending on severity and length of use), replace all seals, wipers, and back-up rings in tool. Service Kits, hoses, and extra parts should be kept in stock. Inspect cylinder bore, pistons, and piston rods for scored surfaces and excessive wear or damage. Replace as necessary.

### NOSE ASSEMBLY MAINTENANCE

Clean nose assembly often. Dip in mineral spirits or similar solvent to clean puller and wash away metal chips and debris. At regular intervals, as experience shows, disassemble nose and use a sharp "pick" to remove imbedded particles from grooves of puller.

\* **DEXRON** is a registered trademark of General Motors Corp.  
**Quintolubric** is a registered trademark of Quaker Chemical Corp.  
**Threadmate** is a registered trademark of Parker Intangibles LLC.  
**TEFLON** is a registered trademark of DuPont Corp.  
**LUBRIPLATE** is a registered trademark of Fiske Brothers Refining Co.



## HYDRAULIC COUPLINGS

FIGURE 5

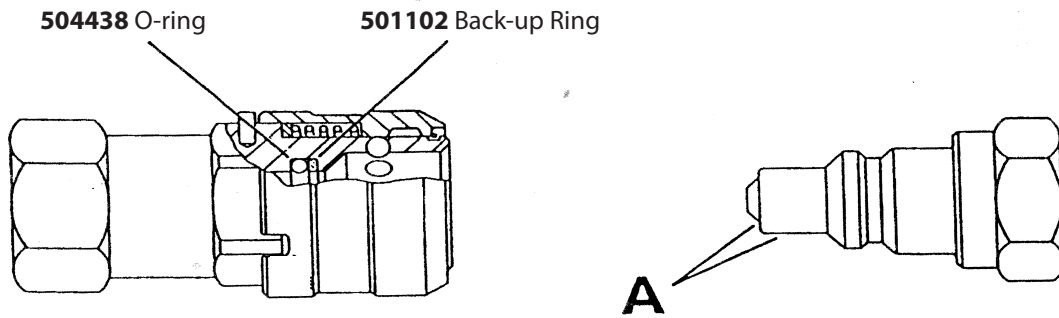

Use a fine India stone to remove any nicks or burrs from diameter **A** and leading edge to prevent damage to O-ring.

## OPTIONAL EQUIPMENT

**TEFLON® Stick** - 503237

**TEFLON® Sealant** - 620012

**Loctite® 243** - 508567

**Never-Seez® NS-160** - 505565  
(anti-seize and lubricating compound)

**LUBRIPLATE® 130-AA** - 502723

**Threadmate™ (4oz. tube)** - 508517

**Pressure Gage** - T-124833CE

**Service Kit** - SF32KIT

**Swage Gage** - HG-S-MBT20 (20mm)  
HG-S-BT24 (3/4")

Hose Assembly	HOSE LENGTH	PART No.
(Contains 2 identical hydraulic hoses with one male and one female quick connect fitting at each end)	- 6 ft	118309-6
	- 12 ft	118309-12
	- 26 ft	118309-26
	- 38 ft	118309-38
	- 52 ft	118309-52

*Loctite* is a registered trademark of Henkel Corporation, U.S.A..

*Never-Seez* is a registered trademark of Bostik, Inc.

*LUBRIPLATE* is a registered trademark of Fiske Brothers Refining Co.

*Threadmate* is a registered trademark of Parker Intangibles LLC..

*TEFLON* is a registered trademark of E. I. du Pont de Nemours and Company.

## STICKER LOCATIONS

This tool comes labeled with important stickers that contain safety and pressure settings information. It is necessary that these stickers remain on the tool and are easily read. If stickers become damaged or worn, or if they have been removed from the tool, they must be replaced. The part numbers are shown in the tool assembly drawing of this manual.



# TOOL COMPONENTS

Figure 4

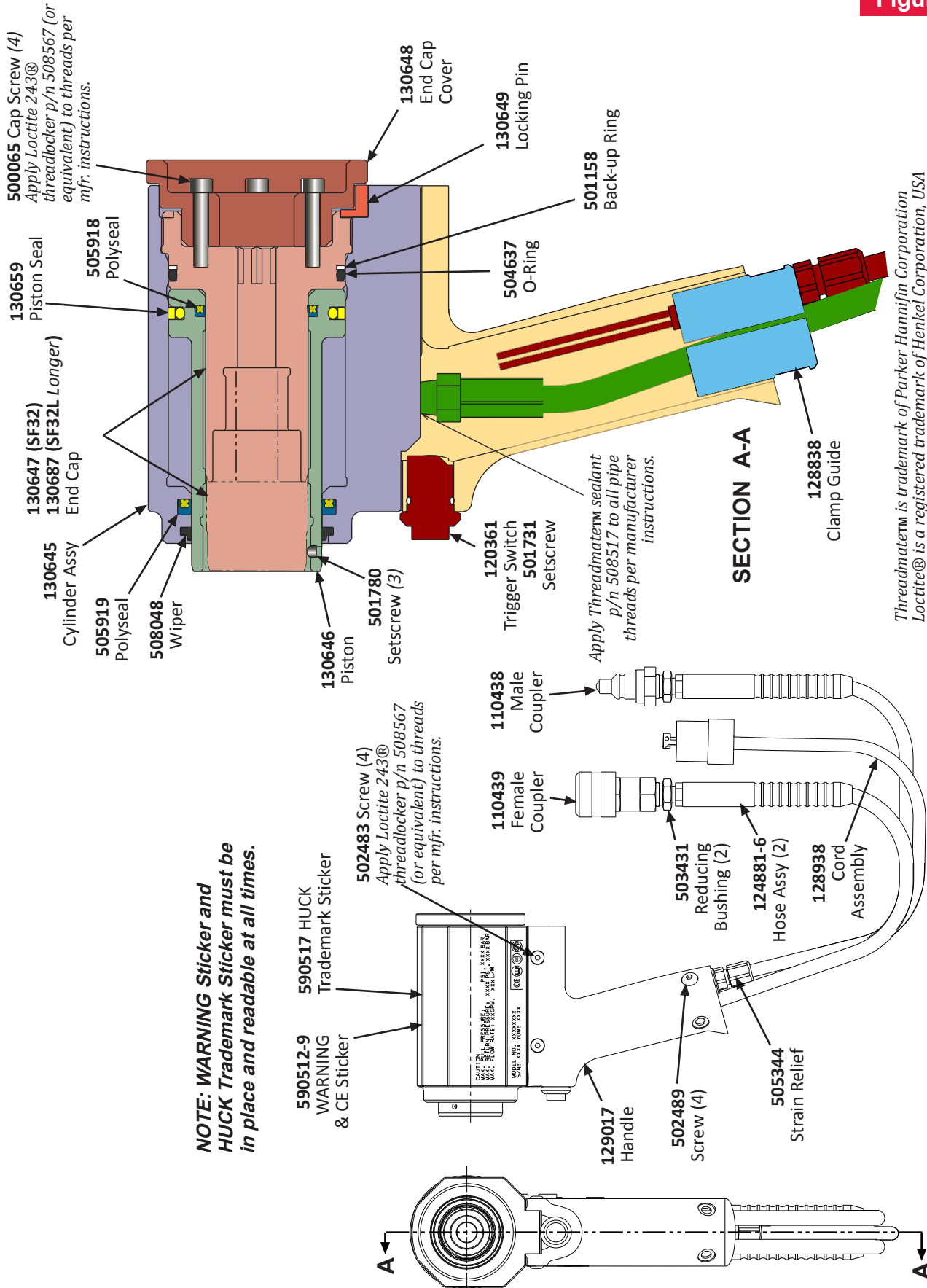

Threadmatern™ is trademark of Parker Hannifin Corporation  
 Loctite® is a registered trademark of Henkel Corporation, USA



## DISASSEMBLY



**WARNING:** Be sure to disconnect tool electrical control trigger system from POWERIG® Hydraulic Unit **BEFORE** disconnecting tool's hydraulic hoses from unit. If not disconnected in this order, severe personal injury may occur.

The following procedure is for complete disassembly. Disassemble only the components necessary to check damaged O-ring, wiper, back-up ring, piston seal, or other components.

1. Disconnect electrical control cord from powerig.
2. Uncouple tool's hydraulic hoses from powerig.
3. Remove nose assembly from tool (see **NOSE ASSEMBLY REMOVAL** below).
4. Remove 4 capscrews and end cap cover.
5. Remove locking pin.
6. Using 5/8 inch hex wrench, unthread end cap from cylinder assembly. Once completely unthreaded, push out from front of tool.
7. Remove 3 setscrews from piston to avoid damaging seals upon reassembly.
8. Push piston out of cylinder from front of tool.
9. Using a small diameter, dull-pointed rod, remove O-ring, back-up rings, wiper, piston seal, and polyseals.

### **NOSE ASSEMBLY REMOVAL**

1. Loosen setscrews on piston.
2. Turn anvil with wrench on flats or spanner wrench, as required. (RH thread)
3. Pull anvil off.
4. Use 9/16 inch hex wrench to remove puller from end cap. (LH thread)

### **SF32L ONLY**

5. Loosen setscrews on anvil holder.
6. Unthread anvil holder (RH thread) using 2 inch wrench on flats.



## ASSEMBLY



### WARNINGS:

Do not omit any seals during servicing, leaks will result and personal injury may occur.

Tool must be fully assembled with all components included.



CAUTION: Do not use TEFLON tape.

### ASSEMBLY PREPARATION:

Clean components in mineral spirits or other solvent compatible with O-ring seals.

Clean out O-ring grooves.

Inspect components for scoring, excessive wear or damage.

Replace O-rings and back-up rings. Be sure that relative positions of the O-rings and back-up rings are as shown in assembly drawing.

Service Kit part number SF20KIT contains O-Rings, Back-up Rings and other seals necessary for servicing this tool.

Smear Lubriplate 130AA on O-rings and mating surfaces to prevent damage to O-rings and to aid assembly.

### ASSEMBLY PROCEDURE:

1. Install wiper and polyseal in cylinder. Note orientation of seals in Figure 4.
2. Install piston seal and polyseal on piston. Note orientation of polyseal in Figure 4.
3. Insert assembled piston into cylinder assembly.
4. Install O-ring and back-up ring on end cap, and insert end cap into back of piston. Using 5/8 inch hex wrench, thread end cap fully into cylinder assembly, then back off until slot in rear of end cap is aligned with slot in rear of cylinder (Figure 5).
5. Slide locking pin into place where slots align (Figure 5).
6. Install end cap cover.

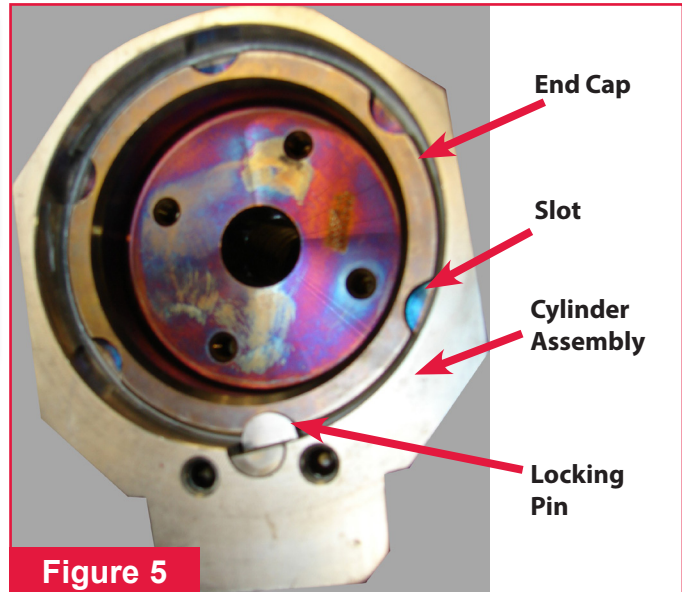

Figure 5

7. Apply Loctite 243 threadlocker to 4 cap screws, and fasten end cap cover into place with screws.
8. Connect tool hoses to powerig hoses.
9. Connect tool electrical trigger plug to powerig, and cycle tool a few times. Observe action of tool and check for leaks.
10. Attach nose assembly to tool following instructions as described below.

### ATTACHING NOSE ASSEMBLY:

#### SF32L ONLY

1. Thread anvil holder into piston (RH thread).
2. Tighten setscrews on piston to lock anvil holder into place.

#### SF32L AND SF32

3. Slide anvil over puller.
4. Thread puller fully into end cap. (LH thread) Use 9/16 hex wrench as necessary to tighten.
5. Thread anvil into piston (SF32) or anvil holder (SF32L). (RH thread)
6. Tighten setscrews on piston (SF32) or anvil holder (SF32L) to lock anvil in place.

*Loctite* is a registered trademark of Henkel Corporation, U.S.A.  
*LUBRIPLATE* is a registered trademark of Fiske Brothers Refining Co.



## Limited Warranties

### Tooling Warranty:

Huck warrants that tooling and other items (excluding fasteners, and hereinafter referred as “other items”) manufactured by Huck shall be free from defects in workmanship and materials for a period of ninety (90) days from the date of original purchase.

### Warranty on “non standard or custom manufactured products”:

With regard to non-standard products or custom manufactured products to customer’s specifications, Huck warrants for a period of ninety (90) days from the date of purchase that such products shall meet Buyer’s specifications, be free of defects in workmanship and materials. Such warranty shall not be effective with respect to non-standard or custom products manufactured using buyer-supplied molds, material, tooling and fixtures that are not in good condition or repair and suitable for their intended purpose.

THERE ARE NO WARRANTIES WHICH EXTEND BEYOND THE DESCRIPTION ON THE FACE HEREOF. HUCK MAKES NO OTHER WARRANTIES AND EXPRESSLY DISCLAIMS ANY OTHER WARRANTIES, INCLUDING IMPLIED WARRANTIES AS TO MERCHANTABILITY OR AS TO THE FITNESS OF THE TOOLING, OTHER ITEMS, NONSTANDARD OR CUSTOM MANUFACTURED PRODUCTS FOR ANY PARTICULAR PURPOSE AND HUCK SHALL NOT BE LIABLE FOR ANY LOSS OR DAMAGE, DIRECTLY OR INDIRECTLY, ARISING FROM THE USE OF SUCH TOOLING, OTHER ITEMS, NONSTANDARD OR CUSTOM MANUFACTURED PRODUCTS OR BREACH OF WARRANTY OR FOR ANY CLAIM FOR INCIDENTAL OR CONSEQUENTIAL DAMAGES.

Huck’s sole liability and Buyer’s exclusive remedy for any breach of warranty shall be limited, at Huck’s option, to replacement or repair, at FOB Huck’s plant, of Huck manufactured tooling, other items, nonstandard or custom products found to be defective in specifications, workmanship and materials not otherwise the direct or indirect cause of Buyer supplied molds, material, tooling or fixtures. Buyer shall give Huck written notice of claims for defects within the ninety (90) day warranty period for tooling, other items, nonstandard or custom products described above and Huck shall inspect products for which such claim is made.

### Tooling, Part(s) and Other Items not manufactured by Huck:

HUCK MAKES NO WARRANTY WITH RESPECT TO THE TOOLING, PART(S) OR OTHER ITEMS MANUFACTURED BY THIRD PARTIES. HUCK EXPRESSLY DISCLAIMS ANY WARRANTY EXPRESSED OR IMPLIED, AS TO THE CONDITION, DESIGN, OPERATION, MERCHANTABILITY OR FITNESS FOR USE OF ANY TOOL, PART(S), OR OTHER ITEMS THEREOF NOT MANUFACTURED BY HUCK. HUCK SHALL NOT BE LIABLE FOR ANY LOSS OR DAMAGE, DIRECTLY OR INDIRECTLY, ARISING FROM THE USE OF SUCH TOOLING, PART(S) OR OTHER ITEMS OR BREACH OF WARRANTY OR FOR ANY CLAIM FOR INCIDENTAL OR CONSEQUENTIAL DAMAGES.

The only warranties made with respect to such tool, part(s) or other items thereof are those made by the manufacturer thereof and Huck agrees to cooperate with Buyer in enforcing such warranties when such action is necessary.

Huck shall not be liable for any loss or damage resulting from delays or non-fulfillment of orders owing to strikes, fires, accidents, transportation companies or for any reason or reasons beyond the control of the Huck or its suppliers.

### Huck Installation Equipment:

Huck International, Inc. reserves the right to make changes in specifications and design and to discontinue models without notice.

Huck Installation Equipment should be serviced by trained service technicians only.

Always give the Serial Number of the equipment when corresponding or ordering service parts.

Complete repair facilities are maintained by Huck International, Inc. Please contact one of the offices listed below.

#### Eastern

One Corporate Drive Kingston, New York 12401-0250  
Telephone (845) 331-7300 FAX (845) 334-7333

#### Outside USA and Canada

Contact your nearest Huck International Office, see back cover.

In addition to the above repair facilities, there are Authorized Tool Service Centers (ATSC’s) located throughout the United States. These service centers offer repair services, spare parts, Service Parts Kits, Service Tools Kits and Nose Assemblies. Please contact your Huck Representative or the nearest Huck office listed on the back cover for the ATSC in your area.

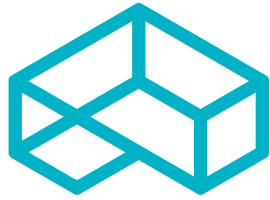

# ARCONIC

Innovation, engineered.

Arconic Inc. (NYSE: ARNC) creates breakthrough products that shape industries. Working in close partnership with our customers, we solve complex engineering challenges to transform the way we fly, drive, build and power.

Through the ingenuity of our people and cutting-edge advanced manufacturing, we deliver these products at a quality and efficiency that ensures customer success and shareholder value.

## **Arconic Fastening Systems and Rings world-wide locations:**

### AMERICAS

#### Kingston Operations

1 Corporate Drive  
Kingston, NY 12401  
800-278-4825  
845-331-7300  
FAX: 845-334-7333

#### Tucson Operations

3724 East Columbia  
Tucson, AZ 85714  
800-234-4825  
520-747-9898  
FAX: 520-748-2142

#### Carson Operations

900 Watson Center Rd.  
Carson, CA 90745  
800-421-1459  
310-830-8200  
FAX: 310-830-1436

#### Acuña Operations

Hidalgo #120  
Parque Industrial Amistad  
26220 Acuña Coahuila  
Mexico  
FAX: 525-515-1776  
TELEX: 1173530 LUKSME

#### Waco Operations

PO Box 8117  
8001 Imperial Drive  
Waco, TX 76714-8117  
800-388-4825  
254-776-2000  
FAX: 254-751-5259

### EUROPE

#### Telford Operations

Unit C, Stafford Park 7  
Telford, Shropshire  
England TF3 3BQ  
01952-290011  
FAX: 0952-290459

#### Us Operations

BP4  
Clos D'Asseville  
95450 Us par Vigny  
France  
33-1-30-27-9500  
FAX: 33-1-34-66-0600

### FAR EAST

#### Melbourne Operations

11508 Centre Road  
Clayton, Victoria  
Australia 3168  
03-764-5500  
Toll Free: 008-335-030  
FAX: 03-764-5510

Huck is Forever, For the Long Haul, The Future of Fastening Technology, The Future of Assembly Technology, The Future of Tooling Technology, and Tools of Productivity are service marks of Huck International. Huck provides technical assistance regarding the use and application of Huck fasteners and tooling.

NOTICE: The information contained in this publication is only for general guidance

with regard to properties of the products shown and/or the means for selecting such products, and is not intended to create any warranty, express, implied, or statutory; all warranties are contained only in Huck's written quotations, acknowledgments, and/or purchase orders. It is recommended that the user secure specific, up-to-date data and information regarding each application and/or use of such products.



**HUCK IS FOREVER.™**