

SKILLS, EXPERTISE & EXPERIENCE

STAR FASTENERS

Key Huck® Fastener supplier to Rail, Engineering & Fabrication Industries

The UK is at the forefront of rail development, liberalisation of the market has fostered competition from global manufacturers and has helped with the generation of new projects and infrastructure improvements. Star Fasteners are a key supplier to the rail and heavy engineering industries and supply fastening solutions to projects around the world. We have the skills, expertise and experience to support customers from design stage through to production and beyond if required, and also have a reputation for being innovative and providing best-in-class products and services.

Star Fasteners are the largest UK distributor for Huck® fasteners, and have been specialists in the sales and distribution of Huck fasteners for over 30 years. Huck fasteners have been designed to cope with extreme stress and vibration, providing strength and facilitating lighter, stronger, more durable structures, they are widely used in a wide variety of tough engineering applications including railcars, rolling stock and track, aerospace, trucks and trailers, bridge construction, mining /quarrying and automotive, in fact anywhere that fastener failure is not an option.

Huck fasteners offer a clean and safe alternative to welding and a more efficient fastening method than standard nuts and bolts, they have additional advantages such as, quick and easy installation, elimination of re-checking / replacement, and ultimately cost reductions. For years, welding was seen as the only way to ensure the integrity of joints in demanding load-bearing or high-vibration structures; companies manufacturing heavy-duty equipment or fabricating large, metal structures continued to employ the universally accepted process of welding joints together. However, today there are alternatives to welding, one of the foremost being direct-tension installed, swaged Lockbolts, such as the HuckBolts®. Each Huck Fastener has its own unique characteristics ensuring that there is a product for every application.



Huck® BobTail® - various sizes and finishes available

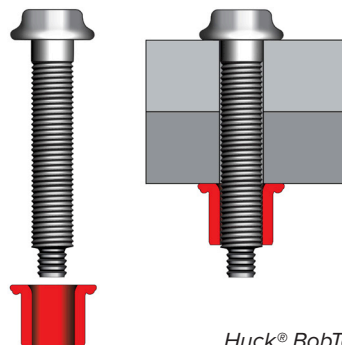

Huck® BobTail® cross-section

THE NEXT STEP IN LOCKBOLT EVOLUTION

A fastener that has become increasingly popular in the UK market is the Huck BobTail®. Regarded as the next step in Lockbolt evolution, the BobTail installs in only two seconds, up to twice as fast as any other large diameter Lockbolt on the market. BobTail has the additional benefit of no pin-break. This not only reduces material waste, it also ensures an improvement in corrosion resistance by eliminating the exposed surface resulting from the pintail break.

The installation system provides a smooth, shock-free process with significantly reduced maximum noise levels, typically less than 70dB. The elimination of the shock load and reduced noise can offer real and significant health and safety benefits.

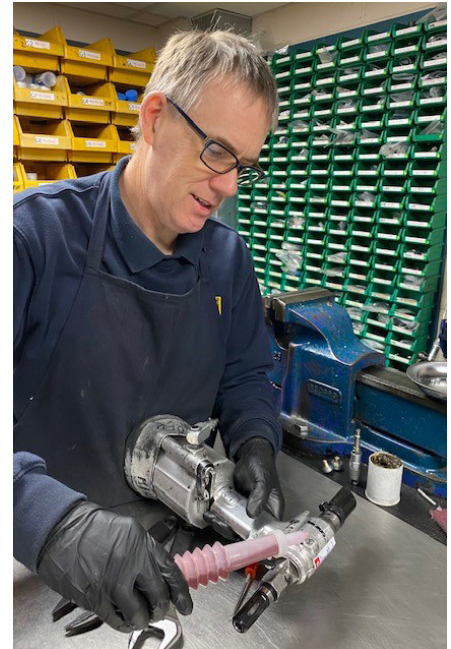

Declared by DIBt (Deutsches Institut für Bautechnik) as 'maintenance free', the 12mm, 14mm, 16mm, 20mm and 1-inch diameter BobTail is now approved to be used in both static and dynamic civil engineering applications. HuckBolt fasteners are now being specified into a wide range of applications that once solely belonged to welding.

HUCK STRUCTURAL BLIND FASTENERS AND STANDARD RIVETS

As well as Huck Lockbolts, Star Fasteners stock a large range of blind fasteners. There are two classes of blind fasteners; structural and non-structural. Huck structural fasteners retain and hold their mandrel after installation, they also have predictable and quantifiable shear and tensile strength. These fasteners can be differentiated from non-structural standard rivets by their overall increased level of strength. Installed Huck structural blind fasteners remain tight up to their minimum mechanical values creating vibration-resistant joints. Many attributes make structural blind fasteners ideal for fastening dissimilar materials, they are also available in a variety of materials, diameters, head styles, coatings, structural strengths and join material through either hole-fill or surface bearing. Easy installation procedures and quick visual inspection guidelines help ensure that each joint is fastened properly, every time.

Huck® Encapsulated Hucktainer®



Huck Range Force™ Battery Tool



Powder coating service

STAR FASTENERS UNIQUE SERVICES

An in-house powder coating service allows any Huck fastener to be coloured to meet customers' requirements. The powder coating service has proved to be popular for both matching the fastener to a project, colour coding for identification purposes and offering additional corrosion / surface protection.

Custom colour encapsulated head. The growing trend for using composites as well as technological improvements has seen innovation in design. With this in mind Star Fasteners brought to the market a coloured encapsulated head Hucktainer®. This Huck fastener was designed specifically for joining light weight composite panels, plastic and fiberglass reinforced plywood to a wide range of materials. With low minimum order quantities and a fast turnaround, the head of the Hucktainer can be matched to any colour of the customer's choice. Its neat appearance gives a professional look to their finished project.

Tool repair and hire service; Star Fasteners accredited Huck tool repair and service department offers expert technical knowledge. We have a dedicated team of experienced engineers, fully trained to the relevant manufacturers' recommendations on key brands such as Huck®, FAR® and Marson®, as well as many other popular brands. Star Fasteners has developed a reputation for providing a personal and reliable service, incorporating nationwide collection and return.

With a fully equipped workshop, Star Fasteners tool services are reliable and timely, so there is minimal down time for the customer and a quick turnaround for every job. Once the tool has been assessed, a quote detailing all parts and costs is raised. If required, Star can guide customers to help find the most economical outcome. Each tool gets a unique reference so Star Fasteners can view its full maintenance history.

Every production environment, workshop and tool benefits from a regular maintenance program and Star Fasteners can help out with that too. We have a large selection of short or long-term hire tools to ensure that production isn't held up. Advising customers on simple maintenance procedures to help prolong the production life of tooling systems are all part of the service.

Star Fasteners also stock a wide range of quality hand, battery and pneudraulic tools that we know can stand up to the rigours of a busy workshop environment. We recognise that choosing a fastener installation tool can be fairly complicated; our service includes demonstrating the latest models and advising on tooling options best suited to both the application and the environment.

WHAT'S NEW? THE HUCK RANGE FORCE™ BATTERY INSTALLATION TOOL

The Range Force battery tool has been designed to combine industry-leading performance with superior reliability. It can install the complete Huck range of structural and non-structural rivets (up to 1/4" / 6.4mm) as well as two-piece fasteners (up to 1/4" BobTail® / Hucktainer® / Magna-Grip® / C6L®). In addition, it boasts exceptional quality for superior durability (tested to 50,000 installations). The high pull force is adjustable and it features a long stroke length, providing considerable versatility. What's more, there's cross-compatibility with Huck nose assemblies and Makita 18v batteries.

COMPANY PROFILE

Star Fasteners has evolved over thirty years to meet the changing needs of the market and now stock an ever-wider range of products in response to the changing marketplace. Our company philosophy is based on principles of quality, service and continuous improvement; this has enabled us to achieve certification to ISO9001:2015 and also Alcumus Safe Contractor accreditation. From products and processes, quality always plays a crucial role and is engrained into Star Fasteners culture.

For more information on our products and services and their potential applications visit starfasteners.co.uk and for tips, ideas and product news follow along on our social media platforms Facebook: @starfasteneruk and LinkedIn, Twitter, Instagram @starfasteners.

Tel: +44(0)115 932 4939
Email: sales@starfasteners.co.uk