

REV	DESCRIPTION	DATE
A	RELEASE	9/30/09

NOTES:

- 1 TO ASSEMBLE:
 A) THREAD LOCKNUT ON PULLER AS SHOWN.
 B) THREAD PULLER IN TOOL'S END CAP.
 C) COLLAPSE PULLER AND TIGHTEN JAM NUT USING WRENCH P/N: 128817
 D) INSTALL ANVIL OVER PULLER AND THREAD INTO TOOL'S PISTON

2 APPLY ANTI-SEIZE LUBRICANT P/N: 508183 OR EQUIVALENT TO OUTSIDE OF PULLER AND INSIDE OF ANVIL.

3 APPLY LOCTITE 242 P/N: 505316 TO THESE THREADED JOINTS PER MFR'S INSTRUCTIONS DURING ASSEMBLY ON TOOL.

4 APPLY WARNING STICKER P/N: 590516 TO ANVIL.

5 LEFT HAND THREAD

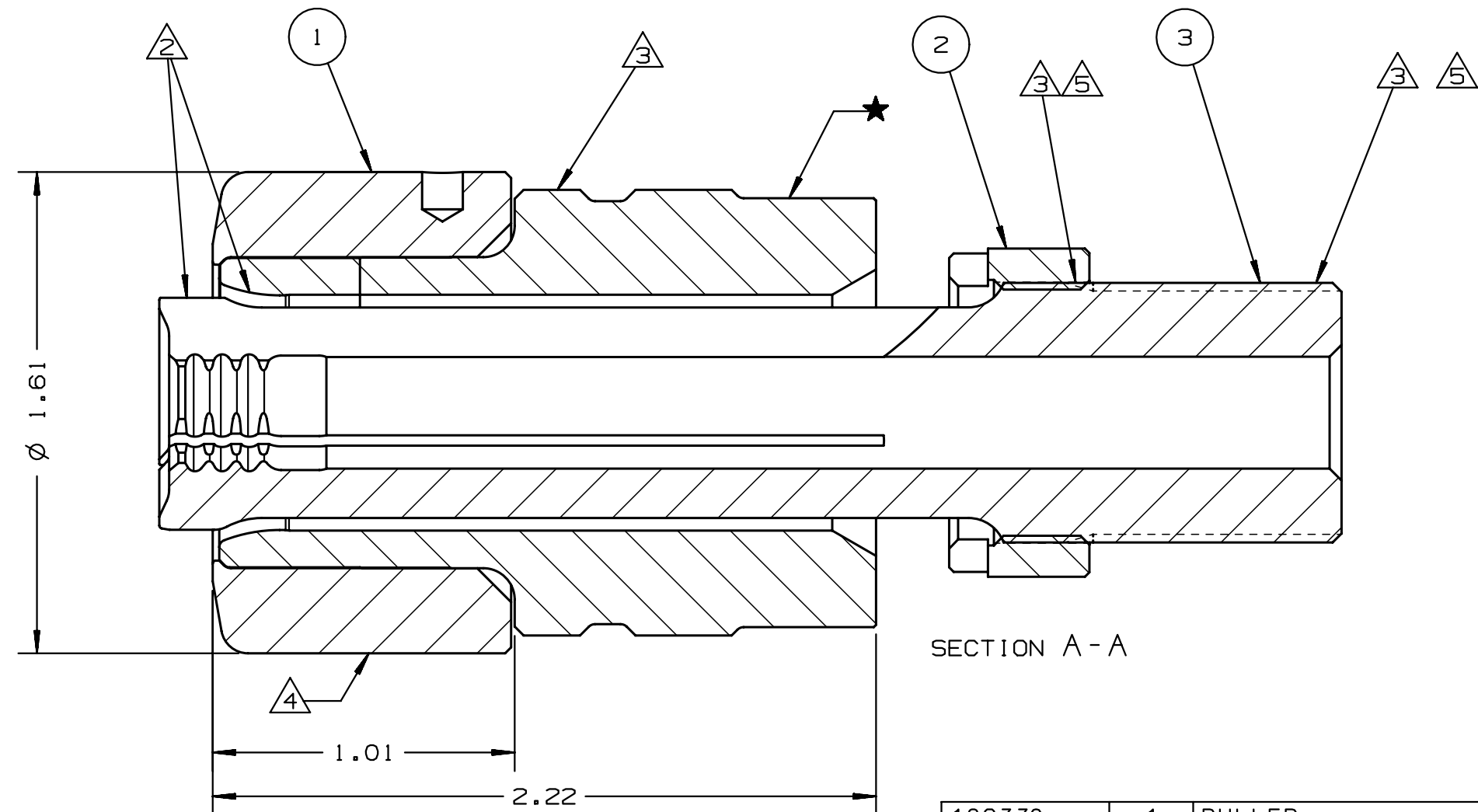
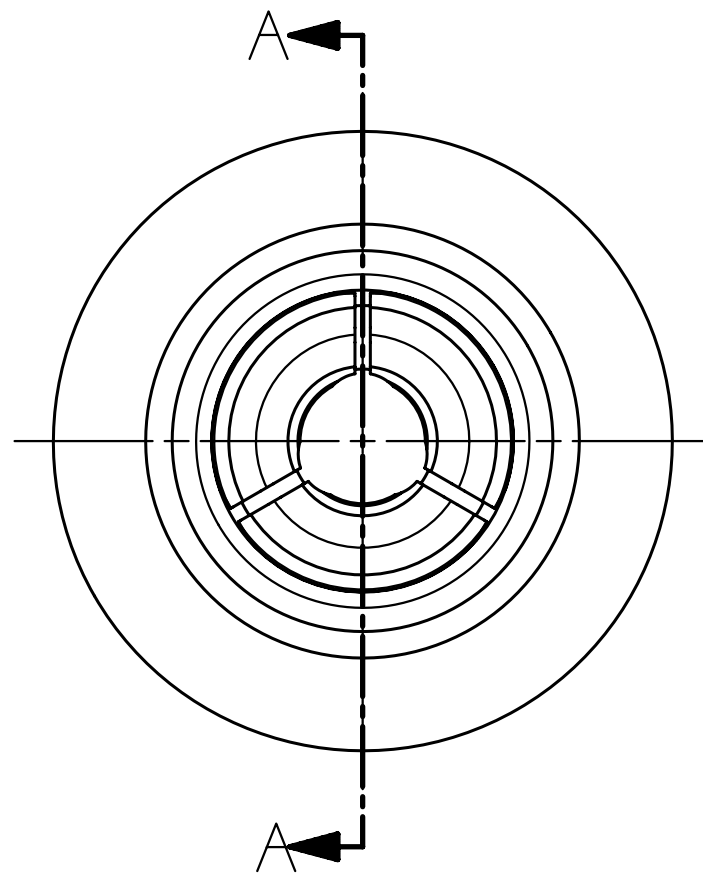

129330	1	PULLER	3
128807	1	LOCK NUT	2
129332	1	ANVIL ASSEMBLY	1
PART NO.	QTY	DESCRIPTION	ITEM

IDENTIFICATION PER SPEC 42-311: ★ PERMANENT	
ITAR:	HUCK INTERNATIONAL, INC., I.S.D.
ECCN: EAR99	NOSE ASSEMBLY, 14MM BOBTAIL BTT20SF TOOL
SCH B#: 8467.99.0190	DET: HKS CK: DATE: 9/30/09 SCALE: 1:1
HTS: 8467.99.0190	B 99-7884