

NOTES:

- 1 TO ASSEMBLE:
 - A) REMOVE ACTUATOR ROD FROM TOOL AND REPLACE WITH ACTUATOR ROD ASSEMBLY (P/N:128863).
 - B) PULLER (P/N:130020) INTO THE END CAP OF THE TOOL UNTIL IT BOTTOMS (LEFT HAND THREAD).
 - C) TIGHTEN THE LOCKNUT USING THE WRENCH (P/N: 128817).APPLY ANTI-SEIZE LUBRICANT P/N: 508183 TO OUTSIDE OF PULLER-130020.
 - D) SLIDE ANVIL HOLDER (P/N: 128810) OVER PULLER AND THREAD INTO TOOL'S PISTON.
 - E) ALIGN ANVIL (P/N: 129971) TO SLOTS IN PULLER, THEN SLIDE INTO ANVIL HOLDER (P/N: 128810). TIGHTEN FOUR SET SCREWS (P/N: 502017)
- 2 APPLY WARNING STICKER P/N: 590273 TO ANVIL HOLDER. DO NOT PERMIT STICKER TO OVERLAP ONTO ANVIL.
- 3 LEFT HAND THREAD

REV	DESCRIPTION	DET	DATE
A	RELEASE	HKS	9/8/11
B	REMOVED 128807 LOCK NUT	CHR	10/04/13
C	REMOVED LOCKNUT/LOCTITE NOTE; REARRANGED NOTE 1; RENAMED DESCRIPTION/TITLE	HKS	08/05/15

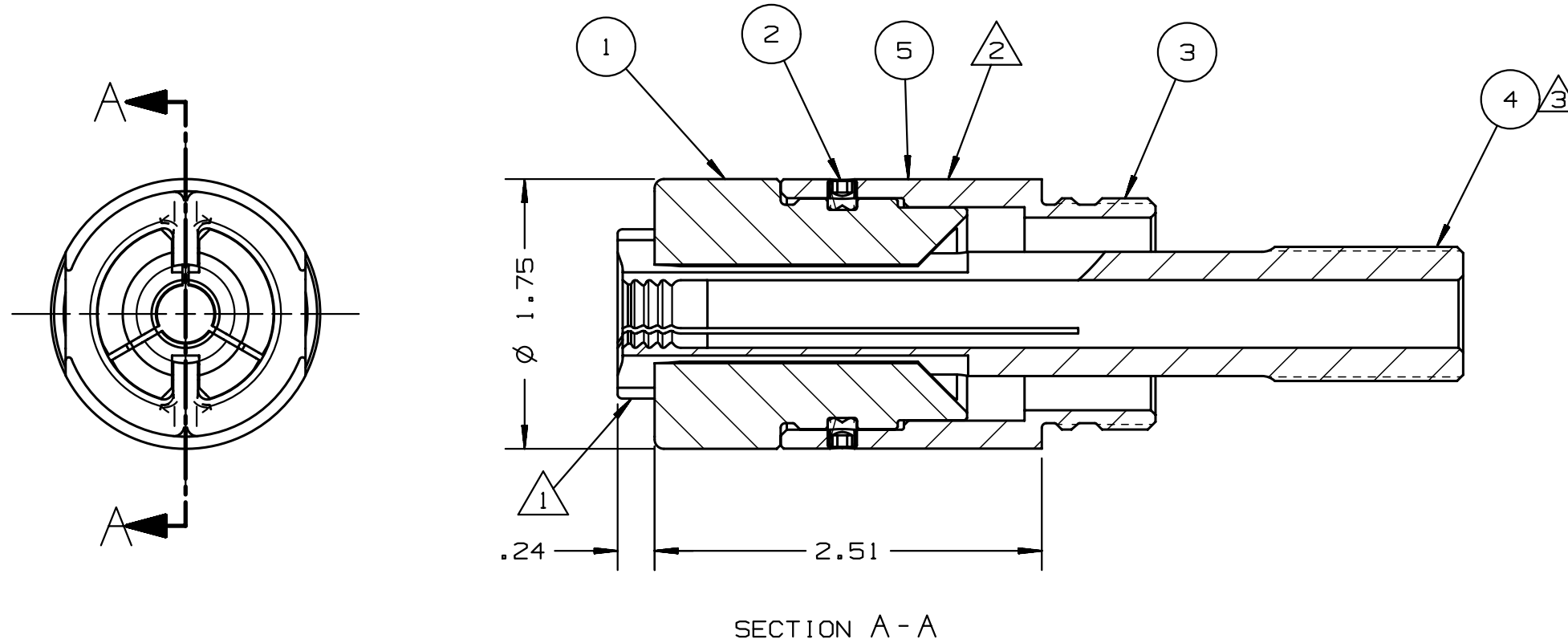

PART NO.	QTY	DESCRIPTION	ITEM
590273	1	WARNING STICKER	5
130020	1	PULLER,CUT,SF20,16MM&-20BT	4
128810	1	ANVIL HOLDER	3
502017	4	SSCR, #10-32 X 3/16	2
129971	1	ANVIL,CUT,BTT35,16MM&-20 BT	1

IDENTIFICATION PER SPEC 42-311: ★ PERMANENT		HUCK INTERNATIONAL, INC., I.S.D 1 CORPORATE DR KINGSTON, NEW YORK 12401	
ITAR/ECCN: EAR99		NOSE, CUT, SF20, 16MM &-20 BT	
SCH B#: 8467.99.0190		FINAL ASSY: -	
ENG: TRK	CK:	DATE: 9/8/11	SCALE: 1:1
HTS: 8467.99.0190		B	99-7881CX