

NOTES:

- 1 TO ASSEMBLE:
 A) THREAD LOCKNUT ON PULLER AS SHOWN.
 B) THREAD PULLER IN TOOL'S END CAP.
 C) COLLAPSE PULLER AND TIGHTEN JAM NUT USING WRENCH P/N: 128817
 D) INSTALL ANVIL OVER PULLER AND THREAD INTO TOOL'S PISTON

② APPLY ANTI-SEIZE LUBRICANT P/N: 508183 OR EQUIVALENT TO OUTSIDE OF PULLER AND INSIDE OF ANVIL.

③ APPLY LOCTITE 242 P/N: 505316 TO THESE THREADED JOINTS PER MFR'S INSTRUCTIONS DURING ASSEMBLY ON TOOL.

Ⓢ ④ APPLY WARNING STICKER P/N: 590273 TO ANVIL.

⑤ LEFT HAND THREAD

REV	DESCRIPTION	DATE
A	RELEASE	7/10/08
B	ADDED NOTE FOR LEFT HAND THREAD P/N: 128817 WAS 128816	4/30/09
C	NOTE 4 P/N 590516 WAS 590273	9/1/09

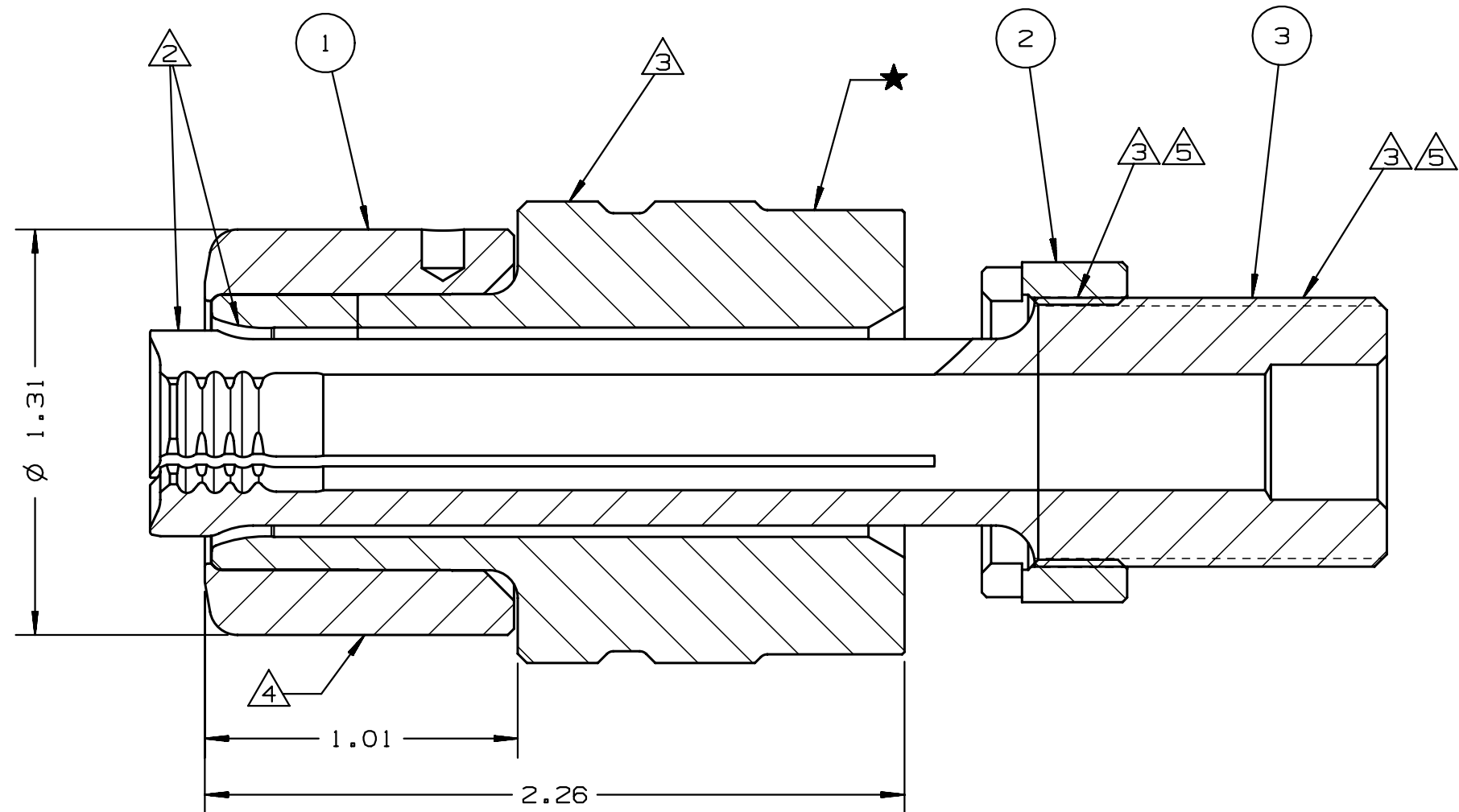
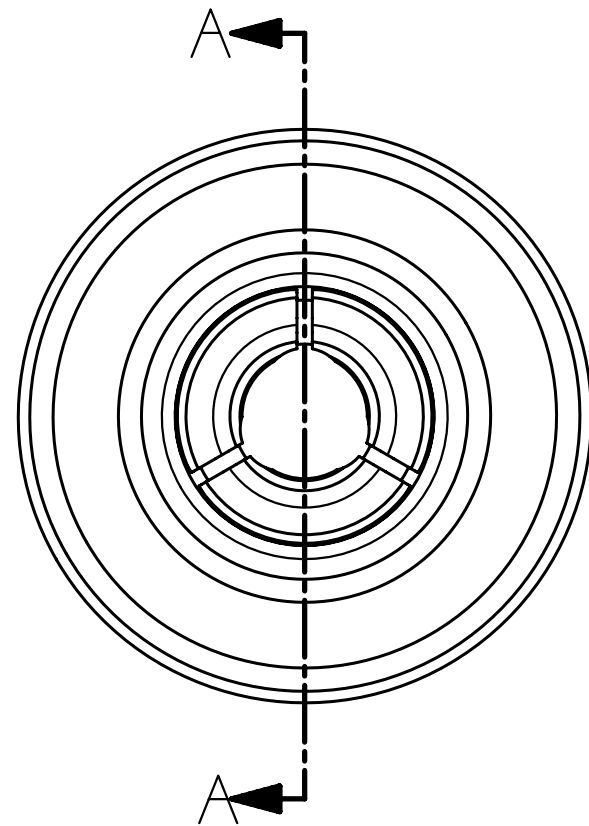

SECTION A - A

128929	1	PULLER	3
128807	1	LOCK NUT	2
128930	1	ANVIL ASSEMBLY	1
PART NO.	QTY	DESCRIPTION	ITEM

IDENTIFICATION PER SPEC 42-311: ★ PERMANENT	
ITAR:	HUCK INTERNATIONAL, INC., I.S.D.
ECCN: EAR99	NOSE ASSEMBLY, 12MM BOBTAIL BTT20SF TOOL
SCH B#: 8467.99.0190	DET: TRK CK: DATE: 7/10/08 SCALE: 1:1
HTS: 8467.99.0190	B 99-7880