

REV	DESCRIPTION	DET	DATE
A	RELEASE	HKS	9/8/11

NOTES:

- 1 APPLY ANTI-SEIZE LUBRICANT P/N:508183 TO OUTSIDE OF PULLER AND INSIDE OF SLEEVE
- 2 APPLY VIBRA-TITE P/N:505125 TO SET SCREW THREADS PER MFR'S INSTRUCTIONS
- 3 APPLY WARNING STICKER P/N:590273 TO ANVIL HOLDER. DO NOT PERMIT STICKER TO OVERLAP ONTO ANVIL

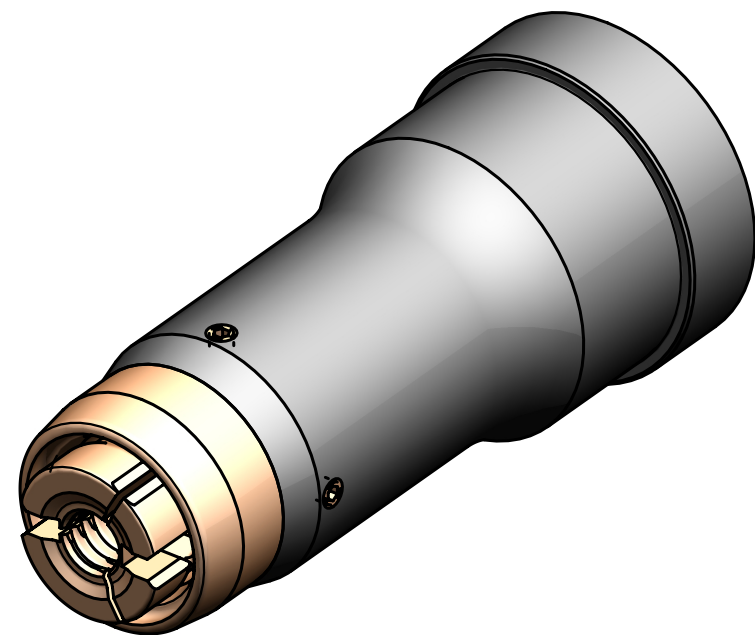
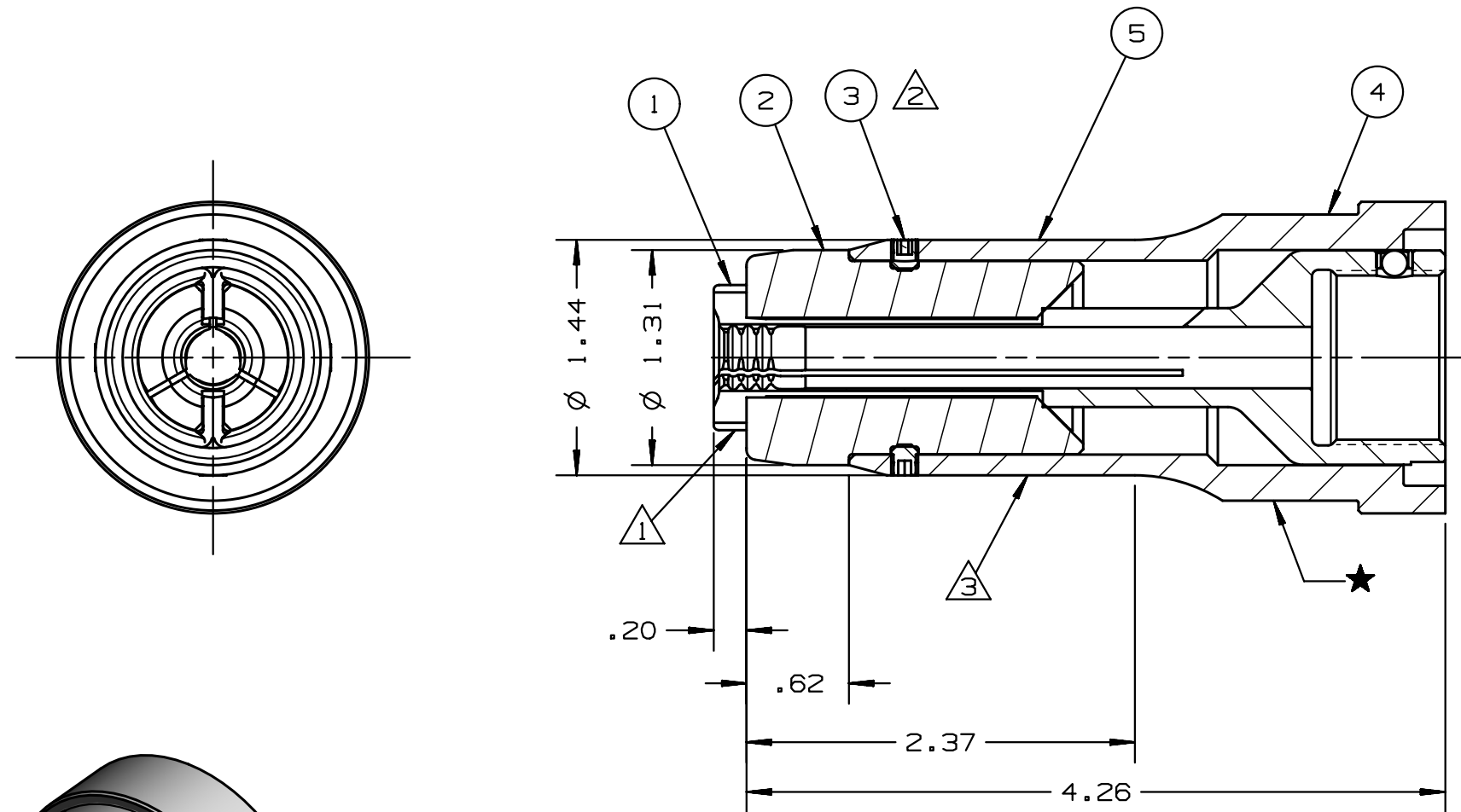

590273	1	WARNING STICKER	5
129450	1	ANVIL HOLDER, COLLAR SPLITTER	4
501781	4	SET SCREW, FLT PT #8-32 X 3/16	3
129975	1	ANVIL, COLLAR SPLITTER	2
130032	1	ASSY, PULLER COLLAR SPLITTER	1
PART NO.	QTY	DESCRIPTION	ITEM

IDENTIFICATION PER SPEC 42-311: ★ PERMANENT	HUCK INTERNATIONAL, INC., I.S.D 1 CORPORATE DR KINGSTON, NEW YORK 12401		
ITAR/ECCN: EAR99	ASSY, MBT-12(12MM)COLLAR SPLITTER 2620 TOOL		
SCH B#: 8467.99.0190	FINAL ASSY: -		
ENG: TRK	CK:	DATE: 9/8/11	SCALE: 1:1
HTS: 8467.99.0190	B	99-7840CX	