

| REV | DESCRIPTION  | DATE    |
|-----|--|---------|
| A   | RELEASE  | 1/7/04  |
| B   | 127772 WAS 127678; ADDED 127774<br>502723 WAS 620030; ADDED NOTE 6 | 4/28/05 |
| C   | REMOVED 127711-4, UPDATED 127573-4                                 | 4/17/06 |

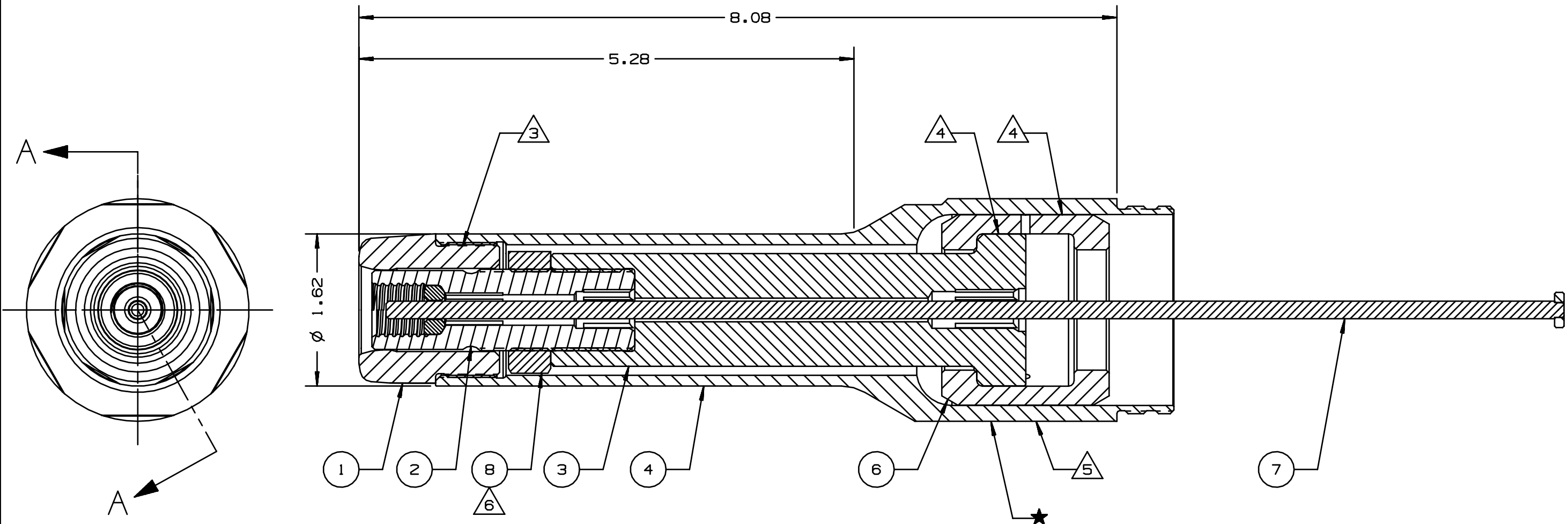

SECTION A - A

NOTES:

- 1 ETCH PER HUCK SPEC 42-311 ★
- 2 USE WITH HSSFT-M16 INSTALLATION TOOL.
- 3 APPLY LOCTITE 242 P/N 505016 TO THESE THREADED JOINTS.
- 4 APPLY LUBRIPLATE P/N 502723 TO SPLIT RINGS.
- 5 APPLY WARNING STICKER P/N 590273 TO ANVIL HOLDER. DO NOT PERMIT STICKER TO OVERLAP ONTO ANVIL.
- 6 TORQUE TO 90-100 LBS-FT.

|   |          |     |                   |      |
|---|----------|-----|-------------------|------|
| B | 127774   | 1   | JAM NUT           | 8    |
|   | 127577-4 | 1   | ACTUATOR ROD ASSY | 7    |
|   | 127570   | 1   | SPLIT RINGS       | 6    |
| C | -        | -   | -                 | 5    |
|   | 127679-4 | 1   | ANVIL HOLDER      | 4    |
|   | 127573-4 | 1   | THIMBLE NUT       | 3    |
| B | 127772   | 1   | THIMBLE ASSY      | 2    |
|   | 126155   | 1   | ANVIL             | 1    |
|   | PART NO. | QTY | DESCRIPTION       | ITEM |

HUCK INTERNATIONAL, INC., I.S.D.  
1 CORPORATE DR., P.O. BOX 2270  
KINGSTON, NEW YORK 12401

NOSE ASSEMBLY  
MHS-14 (14mm) HSSFT-M16 TOOL

DET: TRK [ ] DATE: 1/7/04 SCALE: 1:1

FOC. FAC. B 99-7702-4