

REV	DESCRIPTION	DATE
A	RELEASE	9/30/05

NOTES:

- △1 APPLY LOCTITE 242 P/N: 505016 TO THREADED JOINTS.
- △2 APPLY GREASE P/N: 620030 TO SPLIT RINGS.
- 3 APPLY WARNING STICKER P/N: 590273 TO ANVIL HOLDER. DO NOT ALLOW STICKER TO OVERLAP ON ANVIL.
- △4 TORQUE JAM NUT TO 90-100 LBS-FT

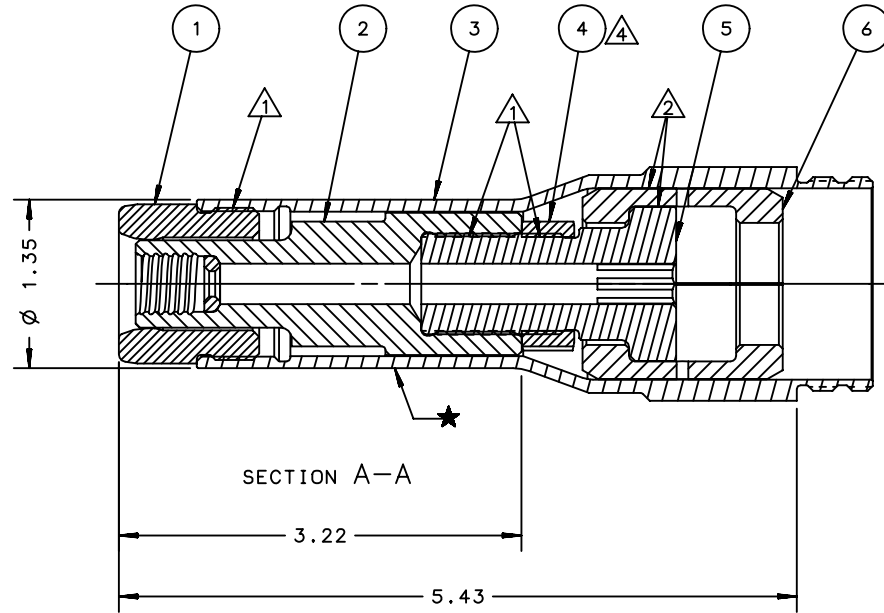
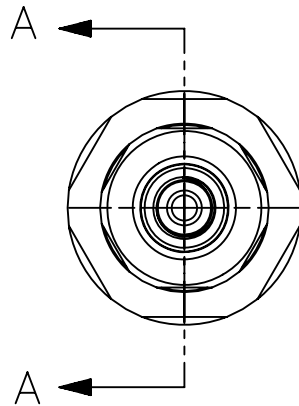

127918	1	SPLIT RINGS	6
127984	1	SPINDLE BOLT	5
124286	1	JAM NUT	4
127985	1	ANVIL HOLDER	3
127987	1	THIMBLE	2
126154	1	ANVIL	1
PART NO.	ITEM	DESCRIPTION	ITEM

FORM KE104 Rev C		By accepting this proprietary Huck drawing, recipient agrees not to reproduce or disclose any part thereof to any other without the written permission of Huck International, Inc.			
MATERIAL:	-	SPEC:	-	TOLERANCES UNLESS OTHERWISE SPECIFIED: (ALL DIMENSIONS ARE IN INCHES)	
HARDNESS:	-	(RAW OR STOCKED STATE)		HUCK INTERNATIONAL, INC., I.S.D. 1 CORPORATE DR., P.O. BOX 2270 KINGSTON, NEW YORK 12401	
HEAT TREAT TO:	-	SPEC:	-	.XX, .XXX ±	.01, .005
SURFACE TREAT:	-	SPEC:	-	INT. COR. RADII	.005-.015
SURFACE FINISH NOT TO EXCEED: 125 Ra		BREAK EDGES		.005-.015	DET: TRK
IDENTIFICATION PER SPEC 42-311: ★ PERMANENT		ANGLES ±		3°	DATE: 9/30/05
SURFACES TO BE ☉, //, ⊕, ⊥, & □ WITHIN .005 T.I.R.		FINAL ASSY:			SCALE: 1:1
				FOC. FAC.	B 99-7700