

NOTES:

1 COLLET AND LOCK ASSEMBLY P/N 122044 CONSISTS OF:  
 COLLET P/N 122039, (NOT AVAILABLE SEPARATELY)  
 RELEASE P/N 127383  
 EJECTOR P/N 127381 AND  
 LOCK ASSEMBLY P/N 101284

2 RELEASE AND EJECTOR KIT P/N 122045 CONSISTS OF:  
 RELEASE P/N 127383 AND  
 EJECTOR P/N 127381

3 ASSEMBLE SLEEVE AND O-RINGS PER HUCK SPEC. #42-491.

4 SHIP WITH CAUTION TAG 590152

5 RELEASE AND EJECTOR TOOL PART# 124751  
 OPTIONALLY AVAILABLE

REV	DESCRIPTION	DATE
B	PICTORIALLY UPDATED	02/26/02
C	ADDED NOTES 5 & 6 127383 RELEASE WAS 122040 RELEASE 127381 EJECTOR WAS 122041 EJECTOR	09/11/03
D	UPDATED DRAWING PICTORIALLY ADDED SPRING 508126 SPRING & 508127 WASHER REMOVED 9 500814 O-RINGS	01/27/04

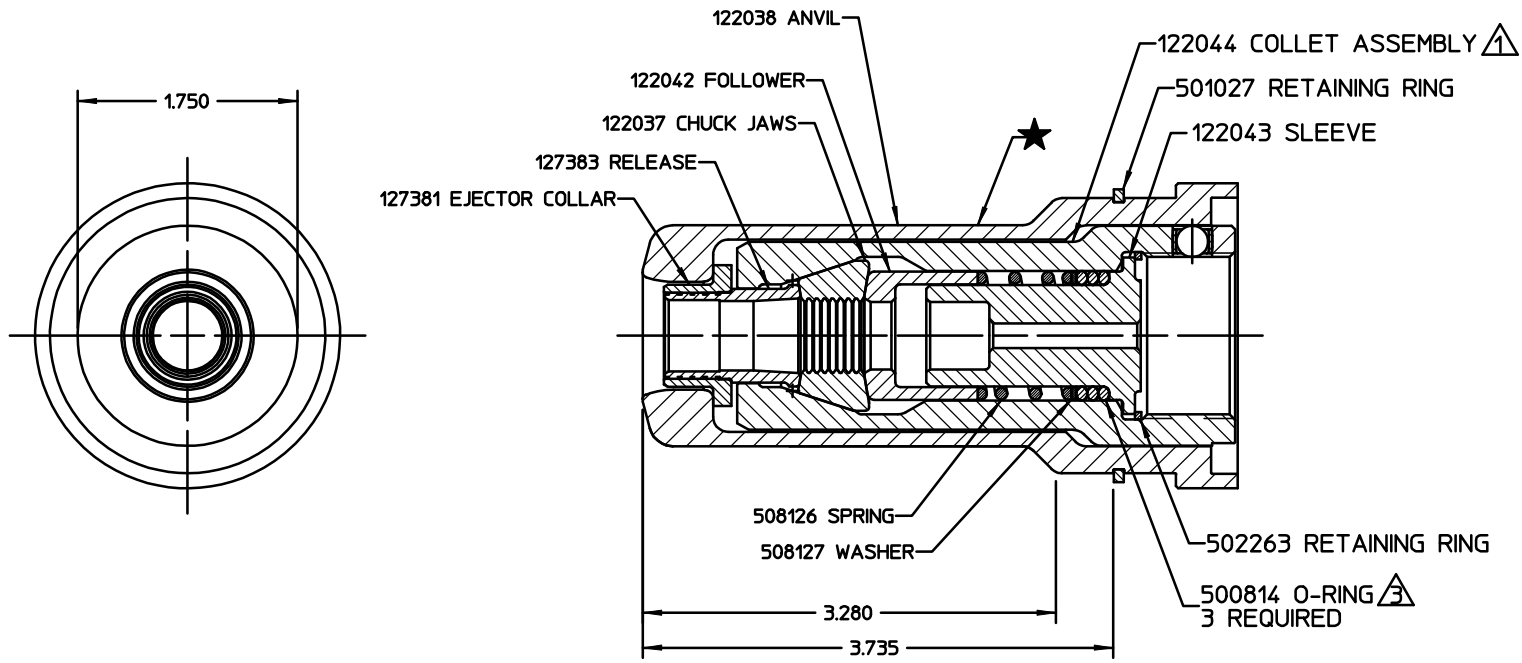

IDENTIFICATION PER SPEC 42-311: ★ ETCH			
HUCK INTERNATIONAL, INC., I.S.D. 1 CORPORATE DRIVE, P.O. BOX 2270 KINGSTON, NEW YORK 12401			
NOSE ASSEMBLY 14MM HP10.9			
DET: TL	CK: -	DATE: 06/13/91	SCALE: FULL
FOC.	B	99-5408	
FAC.			