

DATA SHEET

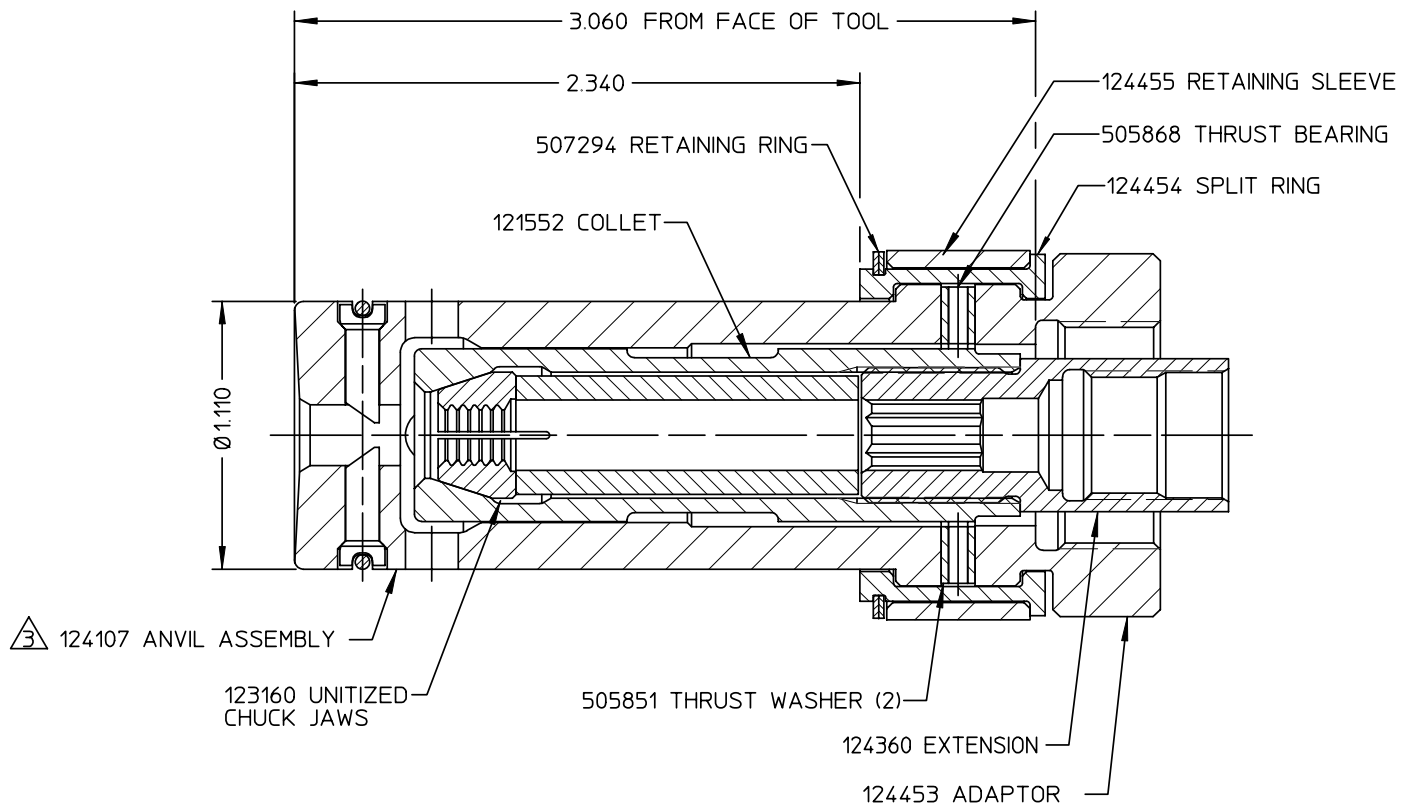
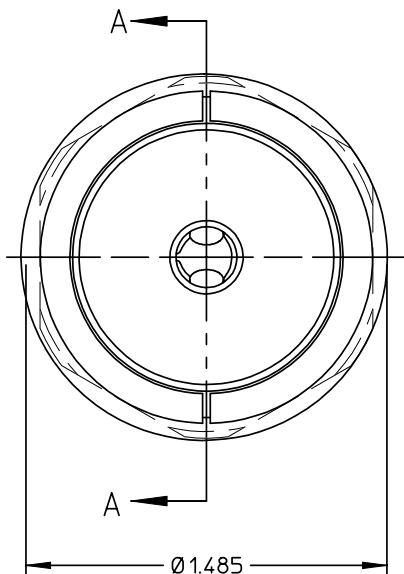

SECTION A-A

Alcoa Fastening Systems

Commercial Products
1 Corporate Drive, Kingston, NY 12401

NOSE TYPE: **NON-SELF-RELEASING**

FASTENER TYPE: **-12 HCLP**

TOOL(S): **212**

Notes:

Product Revision: **A**

US Patent:

Date: **06/18/03**

NOTES:

1 WHEN USED WITH 210 OR 212 TOOLS, USE WITH SHIM P/N 89140 (SHIPPED IN SEPARATE BAG).

2 TORQUE ALL THREADED JOINTS TO 28-32 FT/LBS

△ ANVIL ASSEMBLY 124107 CONSISTS OF:
124106 ANVIL
124105 RATCHET PIN (2)
507166 O-RING

99-3464

Part Number