

Alcoa
Fastening
Systems & Rings



INSTRUCTION MANUAL

256 SERIES

PNEUDRAULIC INSTALLATION TOOLS

ALL MODELS



Makers of Huck®, Marson®, Recoil®
Brand Fasteners, Tools & Accessories

May 21, 2015
HK1015





EC Declaration of Conformity

Manufacturer:

Huck International, LLC, Industrial Products Group, 1 Corporate Drive, Kingston, NY, 12401, USA

Description of Machinery:

Models 24# and 25# pneudraulic installation tools and specials based on their designs (e.g. PR#####).

Relevant provisions complied with:

Council Directive related to Machinery (2006/42/EC)

British Standard related to hand held, non-electric power tools (ISO 11148-1:2011)

European Representative:

Rob Pattenden, Huck International, Ltd. Unit C Stafford Park 7, Telford Shropshire TF3 3BQ, England, United Kingdom

Authorized Signature/date:

I, the undersigned, do hereby declare that the equipment specified above conforms to the above Directive(s) and Standard(s).

Signature:

Full Name: Robert B. Wilcox

Position: Engineering Manager

Location: Huck International, LLC d/b/a Alcoa Fastening Systems
Kingston, New York, USA

Date: 27/03/2013



Declared dual number noise emission values in accordance with ISO 4871

A weighted sound power level, LWA: **91** dB (reference 1 pW)
Uncertainty, KWA: 3 dB

A weighted emission sound pressure level at the work station, LpA: **80** dB
(reference 20 μ Pa)
Uncertainty, KpA: 3 dB

C-weighted peak emission sound pressure level, LpC, peak: **115** dB
(reference 20 μ Pa)
Uncertainty, KpC: 3 dB

Values determined according to noise test code ISO 15744, using as basic standards ISO 3744 and ISO 11203. The sum of a measured noise emission value and its associated uncertainty represents an upper boundary of the range of values which is likely to occur in measurements.

Declared vibration emission values in accordance with EN 12096

Measured Vibrations emission value, a: **.63** m/s²

Uncertainty, K: **.72** m/s²

Values measured and determined according to ISO 28662-1, ISO 5349-2, and EN 1033

Test data to support the above information is on file at Alcoa Fastening Systems, Industrial Products Group, Kingston Operations, Kingston, NY, USA.





EU Declaration of Conformity.....	2
Safety.....	4
Principle of Operation.....	5
Preparation for Use.....	6
Maintenance.....	6
Specifications.....	7
Operating Instructions.....	7
Disassembly.....	8-9
Assembly.....	10
Fill and Bleed.....	11
Assembly Drawings.....	12-13
Troubleshooting.....	14
Accessories.....	14


SAFETY INSTRUCTIONS




GLOSSARY OF TERMS AND SYMBOLS:

 - Product complies with requirements set forth by the relevant European directives.

 - Read manual prior to using this equipment.

 - Eye protection is required while using this equipment.

 - Hearing protection is required while using this equipment.

Notes: are reminders of required procedures.

Bold, Italic type and underlining: emphasizes a specific instruction.

 **WARNINGS:** Must be understood to avoid severe personal injury.

 **CAUTIONS:** Show conditions that will damage equipment or structure.

I. GENERAL SAFETY RULES:

1. A half hour long hands-on training session with qualified personnel is recommended before using Huck equipment.
2. Huck equipment must be maintained in a safe working condition at all times. Tools and hoses should be inspected at the beginning of each shift/day for damage or wear. Any repair should be done by a qualified repairman trained on Huck procedures.
3. For multiple hazards, read and understand the safety instructions before installing, operating, repairing, maintaining, changing accessories on, or working near the assembly power tool. Failure to do so can result in serious bodily injury.
4. Only qualified and trained operators should install, adjust or use the assembly power tool.
5. Do not modify this assembly power tool. This can reduce effectiveness of safety measures and increase operator risk.
6. Do not discard safety instructions; give them to the operator.
7. Do not use assembly power tool if it has been damaged.
8. Tools shall be inspected periodically to verify all ratings and markings required, and listed in the manual, are legibly marked on the tool. The employer/operator shall contact the manufacturer to obtain replacement marking labels when necessary. Refer to assembly drawing and parts list for replacement.
9. Tool is only to be used as stated in this manual. Any other use is prohibited.
10. Read MSDS Specifications before servicing the tool. MSDS specifications are available from the product manufacturer or your Huck representative.
11. Only genuine Huck parts shall be used for replacements or spares. Use of any other parts can result in tooling damage or personal injury.
12. Never remove any safety guards or pintail deflectors.
13. Never install a fastener in free air. Personal injury from fastener ejection may occur.
14. Where applicable, always clear spent pintail out of nose assembly before installing the next fastener.
15. Check clearance between trigger and work piece to ensure there is no pinch point when tool is activated. Remote triggers are available for hydraulic tooling if pinch point is unavoidable.
16. Do not abuse tool by dropping or using it as a hammer. Never use hydraulic or air lines as a handle or to bend or pry the tool. Reasonable care of installation tools by operators is an important factor in maintaining tool efficiency, eliminating downtime, and preventing an accident which may cause severe personal injury.
17. Never place hands between nose assembly and work piece. Keep hands clear from front of tool.
18. Tools with ejector rods should never be cycled with out nose assembly installed.
19. When two piece lock bolts are being used always make sure the collar orientation is correct. See fastener data sheet for correct positioning.

II. PROJECTILE HAZARDS:

1. Risk of whipping compressed air hose if tool is pneudraulic or pneumatic.
2. Disconnect the assembly power tool from energy source when changing inserted tools or accessories.
3. Be aware that failure of the workpiece, accessories, or the inserted tool itself can generate high velocity projectiles.
4. Always wear impact resistant eye protection during tool operation. The grade of protection required should be assessed for each use.
5. The risk of others should also be assessed at this time.
6. Ensure that the workpiece is securely fixed.
7. Check that the means of protection from ejection of fastener or pintail is

in place and operative.

8. There is possibility of forcible ejection of pintails or spent mandrels from front of tool.

III. OPERATING HAZARDS:

1. Use of tool can expose the operator's hands to hazards including: crushing, impacts, cuts, abrasions and heat. Wear suitable gloves to protect hands.
2. Operators and maintenance personnel shall be physically able to handle the bulk, weight and power of the tool.
3. Hold the tool correctly and be ready to counteract normal or sudden movements with both hands available.
4. Maintain a balanced body position and secure footing.
5. Release trigger or stop start device in case of interruption of energy supply.
6. Use only fluids and lubricants recommended by the manufacturer.
7. Avoid unsuitable postures, as it is likely for these not to allow counteracting of normal or unexpected tool movement.
8. If the assembly power tool is fixed to a suspension device, make sure that fixation is secure.
9. Beware of the risk of crushing or pinching if nose equipment is not fitted.

IV. REPETITIVE MOTION HAZARDS:

1. When using assembly power tool, the operator can experience discomfort in the hands, arms, shoulders, neck or other parts of the body.
2. When using tool, the operator should adopt a comfortable posture while maintaining a secure footing and avoid awkward or off balanced postures.
3. The operator should change posture during extended tasks to help avoid discomfort and fatigue.
4. If the operator experiences symptoms such as persistent or recurring discomfort, pain, throbbing, aching, tingling, numbness, burning sensations or stiffness, these warnings should not be ignored. The operator should tell the employer and consult a qualified health professional.

V. ACCESSORIES HAZARDS:

1. Disconnect tool from energy supply before changing inserted tool or accessory.
2. Use only sizes and types of accessories and consumables that are recommended. Do not use other types or sizes of accessories or consumables.

VI. WORKPLACE HAZARDS:

1. Be aware of slippery surfaces caused by use of the tool and of trip hazards caused by the air line or hydraulic hose.
2. Proceed with caution while in unfamiliar surroundings; there could be hidden hazards such as electricity or other utility lines.
3. The assembly power tool is not intended for use in potentially explosive environments.
4. Tool is not insulated against contact with electrical power.
5. Ensure there are no electrical cables, gas pipes, etc., which can cause a hazard if damaged by use of the tool.

VII. NOISE HAZARDS:

1. Exposure to high noise levels can cause permanent, disabling hearing loss and other problems such as tinnitus, therefore risk assessment and the implementation of proper controls is essential.
2. Appropriate controls to reduce the risk may include actions such as damping materials to prevent workpiece from 'ringing'.
3. Use hearing protection in accordance with employer's instructions and as required by occupational health and safety regulations.
4. Operate and maintain tool as recommended in the instruction handbook to prevent an unnecessary increase in the noise level.
5. Select, maintain and replace the consumable / inserted tool as recommended to prevent an unnecessary increase in noise.
6. If the power tool has a silencer, always ensure that it is in place and in good working order when the tool is being operated.

VIII. VIBRATION HAZARDS:

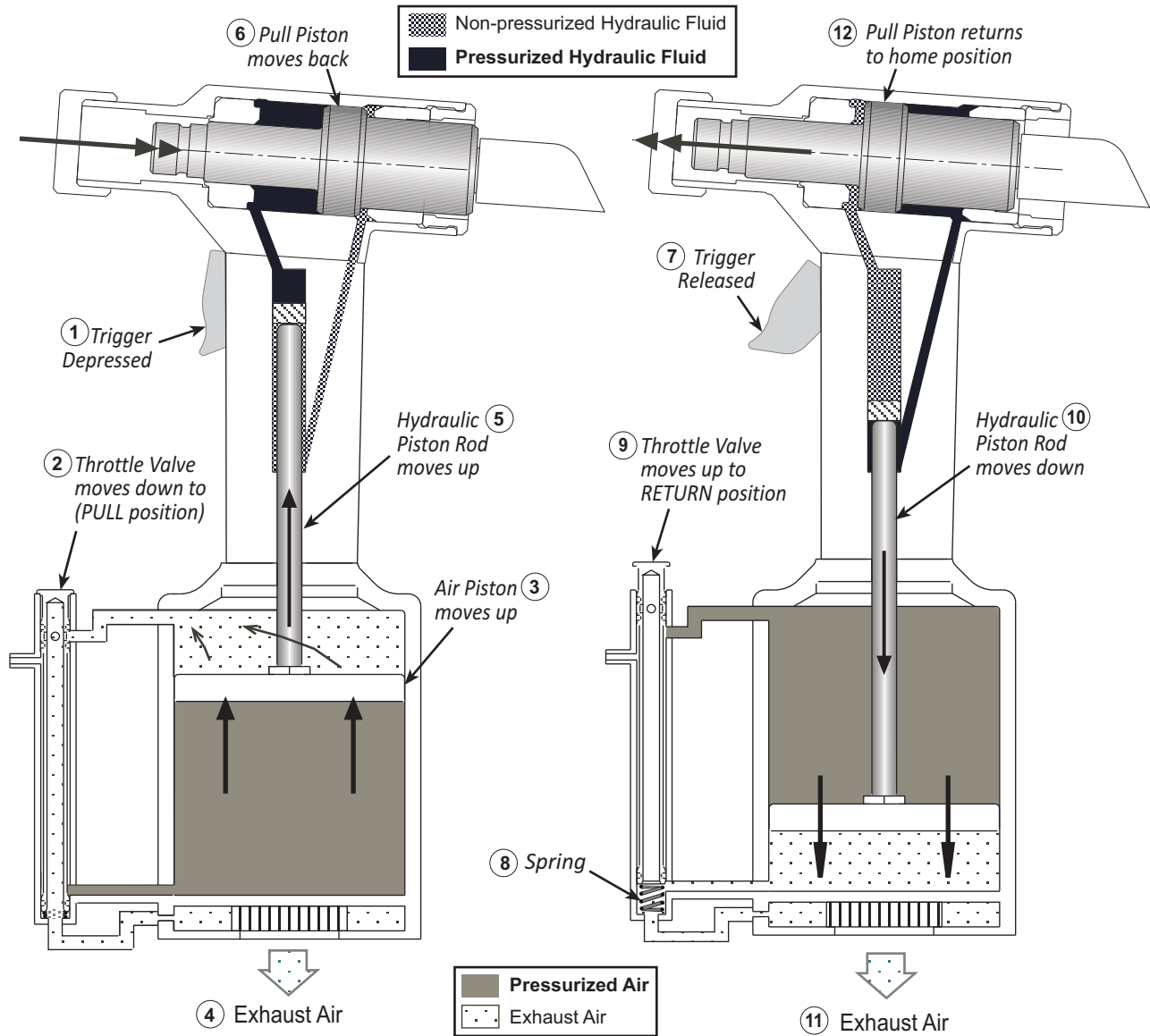
1. Exposure to vibration can cause disabling damage to the nerves and blood supply to the hands and arms.
2. Wear warm clothing when working in cold conditions and keep hands warm and dry.
3. If numbness, tingling, pain or whitening of the skin in the fingers or hands, stop using the tool, tell your employer and consult a physician.
4. Support the weight of the tool in a stand, tensioner or balancer in order to have a lighter grip on the tool.

IX. PNEUMATIC / PNEUDRAULIC TOOL SAFETY INSTRUCTIONS:

1. Air under pressure can cause severe injury.
2. Always shut off air supply, drain hose of air pressure and disconnect tool from air supply when not in use, before changing accessories or when making repairs.
3. Never direct air at yourself or anyone else.
4. Whipping hoses can cause severe injury, always check for damaged or loose hoses and fittings.
5. Cold air should be directed away from hands.
6. Whenever universal twist couplings (claw couplings) are used, lock pins shall be installed and whipcheck safety cables shall be used to safeguard against possible hose to hose or hose to tool connection failure.
7. Do not exceed maximum air pressure stated on tool.
8. Never carry an air tool by the hose.



PRINCIPLE OF OPERATION



When the Trigger is depressed (1), the Throttle Valve moves to the down position (2), and pressurized air is directed to the bottom of the Air Piston, causing it to move upward (3). The air above the Piston is exhausted and directed through the center of the Throttle Valve and out the bottom of the tool (4). The Air Piston has a Rod and a Hydraulic Piston attached. When the Air Piston rod moves upward, a column of pressurized hydraulic fluid is forced up (5) into the tool head, which moves the Pull Piston back (6). The attached nose assembly moves with the Pull Piston to start fastener installation.

When fastener installation is completed, the Trigger is released (7). Air pressure, with the assistance of a Spring (8), causes the Throttle Valve to return to its up position (9). Pressurized air is re-directed to the top of the Air Piston, causing it, along with the Hydraulic Piston Rod, to move downward (10). The air from below the Air Piston is exhausted through the bottom of the tool (11). As this occurs, hydraulic pressure is reversed and the Pull Piston is returned forward (12). A return pressure relief valve protects the tool against pressure spikes. The reservoir replenishes the hydraulic system as needed.

PREPARATION FOR USE



The Model 256 Installation Tool is shipped with a plastic plug in the air inlet connector. The connector has 1/4-18 female pipe threads to accept the air hose fitting. Quick disconnect fittings and 1/4" inside diameter air hose are recommended. An air supply of 90-100 psi capable of 22.4 CFM must be available. Air supply should be equipped with a filter-regulator-lubricator unit.

1. Remove plastic shipping plug from air inlet connector and put in a few drops of Automatic Transmission Fluid, DEXRON III, or equivalent.
2. Apply TEFLON in stick form to threads of Air Hose, and screw hose into the tool.

Caution: Do not use TEFLON tape on threads. Use only in stick form: Huck P/N 503237.

3. Set air pressure on regulator to 90-100 psi.
4. Screw air fitting (not supplied with tool) into Air Hose and connect to air source. Quick disconnect fitting into Air Inlet Connector, or screw quick disconnect fitting into Air Inlet Connector, then attach optional Air Hose supplied with tool.
5. Cycle tool a few times by depressing and releasing trigger.

6. Disconnect air hose from tool.
7. Remove retaining nut and stop.
8. Select proper nose assembly for fastener to be installed.
9. Screw collet assembly, including lock collar and shim, if applicable, onto spindle holding Hydraulic Pull Piston of tool with 3/8 hex key. Wrench tight.
10. Slide nose assembly anvil over collet assembly and into counterbore.
11. Slide tool's Stop and Retaining Nut over nose assembly anvil and screw Nut onto tool head.
12. Connect air hose to tool and install fastener(s) in a test plate of proper thickness with proper size holes. Inspect fastener(s).

NOTE: Threadmate® should be used on collet threads for nose assemblies without lock collars. All other noses should be staked.

*Threadmate is a registered trademark of Parker Intangibles LLC
TEFLON is a registered trademark of DuPont Corporation.*

MAINTENANCE



GENERAL

1. The efficiency and life of any tool depends upon proper maintenance. Regular inspection and correction of minor problems will keep tool operating efficiently and prevent downtime. The tool should be serviced by personnel who are thoroughly familiar with how it operates.
2. A clean, well-lighted area should be available for servicing the tool. Special care must be taken to prevent contamination of pneumatic and hydraulic systems.
3. Proper hand tools, both standard and special, must be available.
4. All parts must be handled carefully and examined for damage or wear. Always replace Seals, when tool is disassembled for any reason. Components should be disassembled and assembled in a straight line without bending, cocking, or undue force. Disassembly and assembly procedures outlined in this manual should be followed.
5. Service Parts Kit 256KIT includes consumable parts and should be available at all times. Other components, as experience dictates, should also be available.



WARNING: Inspect tool for damage or wear before each use. Do not operate if damaged or worn, as severe personal injury may occur.

DAILY

1. If a Filter-Regulator-Lubricator unit is not being used, uncouple air disconnects and put a few drops of Automatic Transmission Fluid or light oil into the air inlet of the tool. If the tool is in continuous use, put a few drops of oil in every two to three hours.
2. Bleed the air line to clear it of accumulated dirt or water before connecting air hose to the tool.
3. Check all hoses and couplings for damage or air leaks, tighten or replace if necessary.
4. Check the tool for damage or air/hydraulic leaks, tighten or replace if necessary.
5. Check the nose assembly for tightness or damage, tighten or replace if necessary.
6. Check oil level in tool reservoir, replenish if necessary.

WEEKLY

1. Disassemble and clean nose assemblies and reassemble.
2. Check the tool and all connecting parts for damage or oil/air leaks, tighten or replace if necessary.



SPECIFICATIONS

POWER SOURCE:

90psi MAX shop air

HOSE KITS:

Use only genuine HUCK Hose Kits rated @ 10,000 psi working pressure.

HYDRAULIC FLUID:

Hydraulic fluid shall meet DEXRON® III, DEXRON VI, MERCON, Allison C-4 or equivalent ATF specifications.

Fire resistant fluid may be used if it is an ester based fluid such as Quintolubric HFD or equivalent. Water based fluid shall NOT be used as serious damage to equipment will occur.

WEIGHT:

11.1 lbs (5.03 kg)

MAX OPERATING TEMP:

125°F (51.7°C)

SPEED/CYCLES:

30 per minute

MAX FLOW RATE:

22.4 scfm (634 l/m)

MIN PULL CAPACITY:

9986 lbs (44.42 kN) @ 90 psi

MAX INLET PRESSURE:

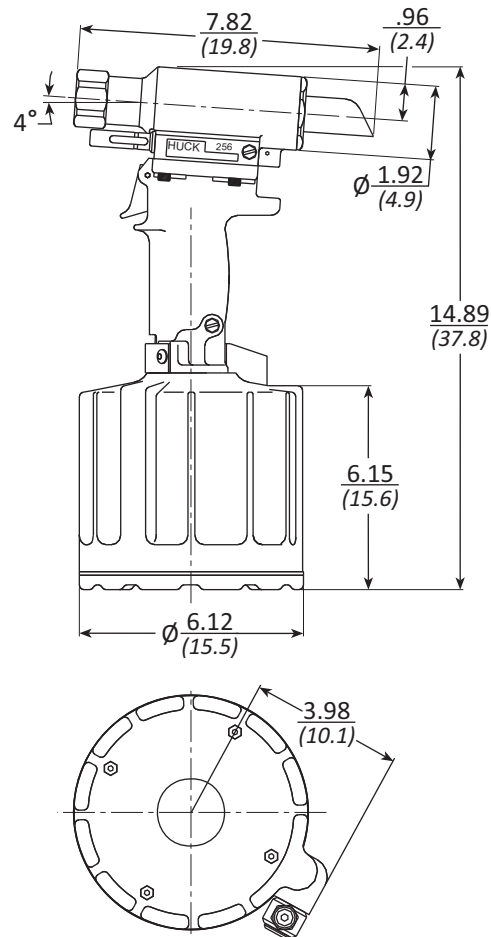
90 psi (6.2 bar)

MIN STROKE:

.875 inches (2.22 cm)

.750 inches (1.91 cm) when used with Stroke Limiter 118362-1

DEXRON is a registered trademark of General Motors Corporation.



OPERATING INSTRUCTIONS

NOTES: Failure to understand WARNINGS may cause serious personal injury.
Failure to understand CAUTIONS may cause damage to structure and Tool.
For additional Safety Information, see page 4.

LOCKBOLT® FASTENER INSTALLATION:



WARNING: Do not pull on a pin without a collar. The pin will eject with velocity and force when the pintail breaks off. This may cause serious injury.



CAUTION: Remove excess gap from between the sheets. This permits enough pintail to emerge from collar for ALL jaw teeth to engage with pintail. If ALL teeth do not engage properly, jaws will be stripped/damaged.

Place pin in work hole and place collar over pin. See WARNING. (If Collar has only one tapered end, that end must be facing toward tool, not next to workpiece.) Hold pin and push nose assembly onto pin protruding through collar until nose assembly anvil touches collar. Depress trigger and hold depressed until collar is swaged and pintail breaks. Release trigger and tool will go into return stroke. The tool and nose assembly are ready for the next fastener installation cycle.

BLIND FASTENER INSTALLATION:



WARNING: Do not pull on a fastener's pin without first placing fastener in a work piece. The fastener will eject forcibly when the pintail breaks off. This may cause serious injury.



CAUTION: To avoid structural and Tool damage, be sure enough clearance is allowed for nose assembly at full stroke. Do not abuse the tool by dropping it, using it as a hammer or otherwise causing unnecessary wear and tear. Reasonable care of installation tools by operators is an important factor in maintaining tool efficiency and reducing downtime.

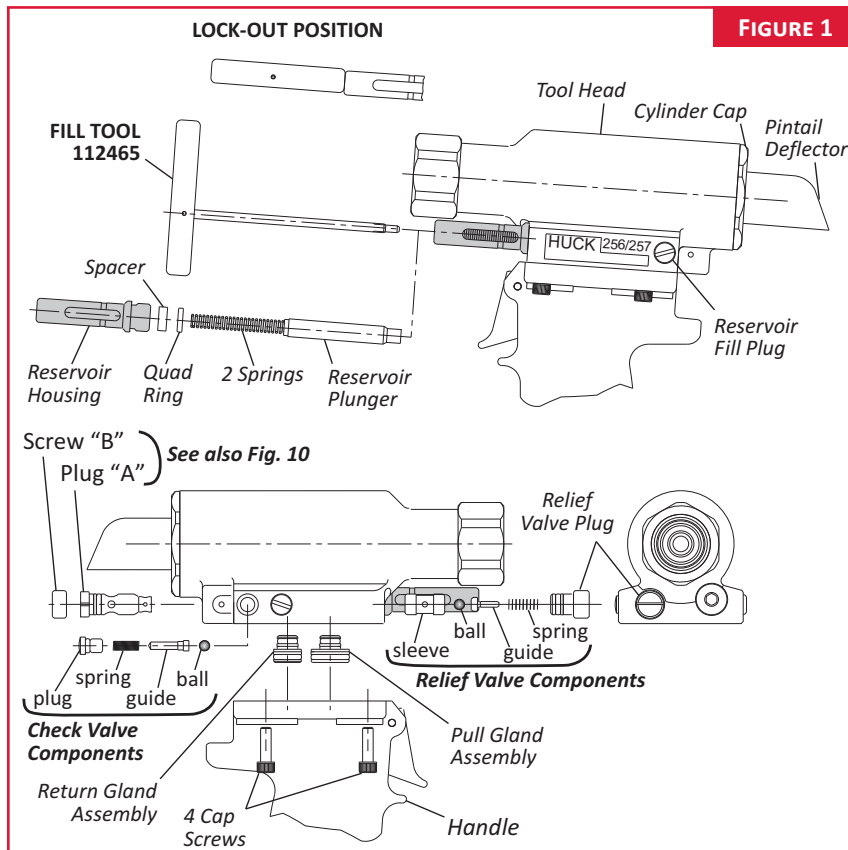
Remove excess gap from between the sheets to permit correct fastener installation. Fastener may be placed in work hole or in end of nose assembly. See WARNING. In either case, tool and nose assembly must be held against work and at right angles to it. Depress trigger and hold it depressed until fastener is installed and pintail breaks. Release trigger and tool will go into its return stroke. The tool and nose assembly are ready for next fastener installation cycle.

DISASSEMBLY

WARNING: Be sure air hose is disconnected from tool before cleaning or performing maintenance. Severe personal injury may occur if air hose is not disconnected.

For component identification and parts list, refer to Figures 1-4, 10, & 11. **NOTE:** The following procedure is for complete disassembly of tool. Disassemble **only** components necessary to replace damaged O-rings, Quad rings, Back-up rings, and worn or damaged components. Always use soft-jaw vice to avoid damage to tool.

1. Disconnect air hose from tool.
2. Remove nose assembly.
3. (Fig. 1) Insert Fill Tool through reservoir housing and screw into Reservoir Plunger, locking it in the out position.
4. Unscrew 4 Cap Screws with 5/32 hex key. Carefully lift Tool Head straight up from Handle, and remove Pull and Return Gland Assemblies. Remove seals from glands.
5. Unscrew Relief Valve Plug from front of head. Remove Relief Valve Spring, Guide, Sleeve and Ball. A small magnet is helpful.
6. Unscrew Reservoir Fill Plug. Hold over waste oil container and release fill tool slowly.
7. Unscrew Reservoir Housing from head. Remove 2 Springs. Slide Reservoir Plunger from head. Remove spacer and Quad Ring. A pick may be used to remove the quad ring.
8. Unscrew Check Valve Plug from side of head. Remove Check Valve Spring, Guide, and Ball. A small magnet is helpful. (Fig. 1)
9. If Check Valve Seat (Fig. 10) is damaged, contact your HUCK representative. If Relief Valve Seat (Fig. 10) is damaged, it can be removed by using the procedure described in step 10. **NOTE: If seats are removed, they may not be reused; they must be replaced.**
10. **RELIEF VALVE SEAT ASSEMBLY REMOVAL** (Figs. 1 & 10) **Note: All parts in check valve hole must be removed before Plug "A" can be removed.** Unscrew Screw "B". Insert a #10 screw in the thread of Plug "A", and pull to remove. Using a small drift and hammer, from rear side of head, drive Relief Valve Seat Assy (Fig. 10) out toward the front of the head.
11. Pintail Deflector can be pulled off barbed end at rear of Hydraulic Pull Piston.

**FIGURE 1**

12. Unscrew Cylinder Cap from Cylinder/Head using a 1-9/16 open-end wrench.

13. (Fig. 2) Place Spacer on Hydraulic Pull Piston, and screw Assembly/Disassembly Bullet onto piston. Tap or press piston assembly out of head. **NOTE: This will push out front and rear gland assemblies and wiper and wiper housing.**

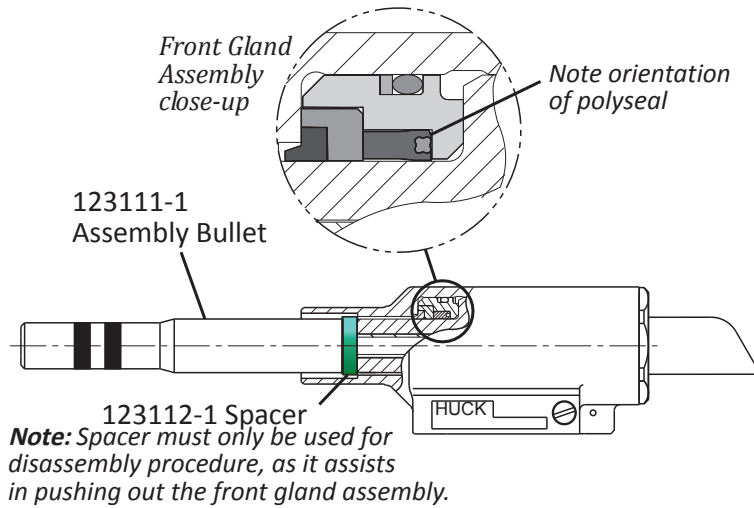
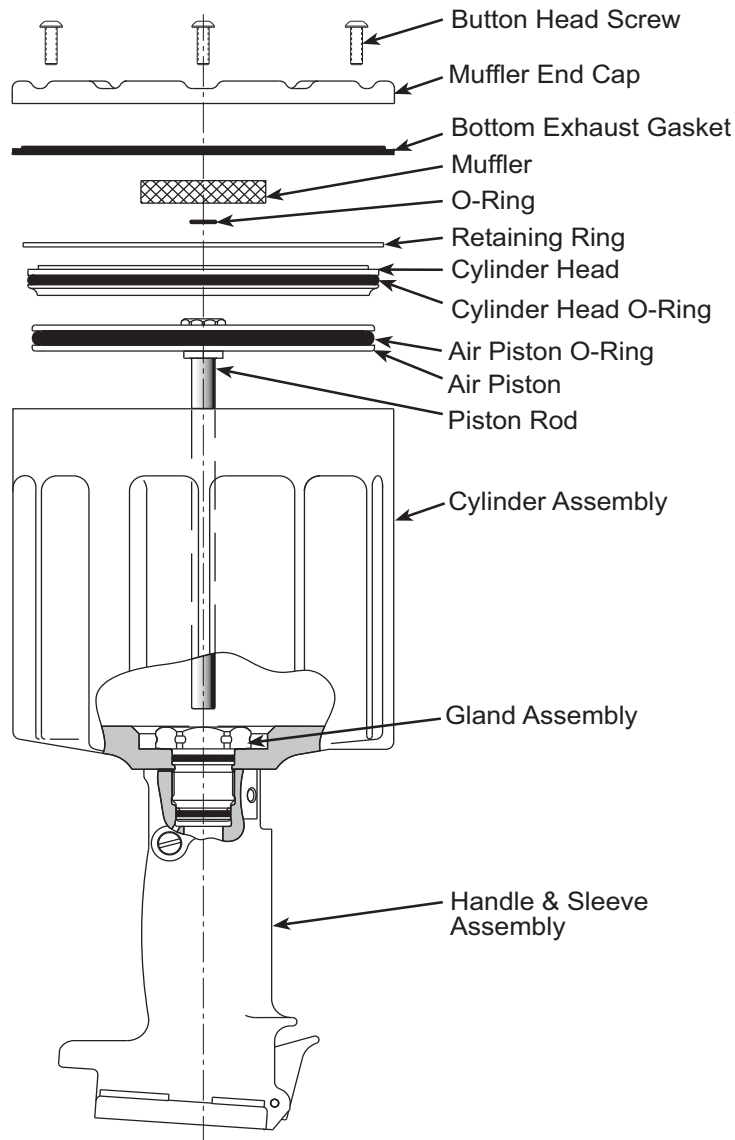
14. (Fig. 11) Remove Throttle Arm Screw from Throttle Arm, then remove Throttle Arm. Pull Throttle Valve out of cylinder. Remove Throttle Spring.

15. (Fig. 10) With a small punch and hammer, drive Trigger Pin that retains the Trigger from Handle. Remove Cable Pin. Remove ball end of Cable from Throttle Arm (Fig. 11), and pull cable out of handle.

16. Remove Reservoir Fill Plug from handle. (Fig. 10)



DISASSEMBLY *continued*

FIGURE 2

FIGURE 3


17. (Fig. 3) Hold tool inverted in vice. Unscrew 3 Button Head Screws with 1/8 hex key.

18. Remove Muffler End Cap, Bottom Exhaust Gasket, Muffler and O-ring.

19. Remove Retaining Ring from Cylinder Assembly. **NOTE: Tap Cylinder Head down into Cylinder Assembly for easier removal of Retaining Ring.**

20. Screw Button Head Screws into Cylinder Head, and carefully pry under screws to remove Cylinder Head.

21. Push Air Piston all the way down in cylinder and lay tool on its side. Hold Self-locking Nut with a 9/16 socket and extension and, with 7/64 hex key, remove Intensifier Piston Screw (Fig. 4).

22. Turn cylinder and handle upside down and secure in a vise.

23. Grip Self-locking Nut under Air Piston with pliers and pull piston and rod assembly from handle and cylinder assembly. (Fig. 3 & 4)

Caution: Care must be given not to scratch piston rod or cylinder during removal.

24. With a 1 3/8 socket and extension, remove Gland Assembly. Handle and cylinder will now separate. (Fig. 3)

25. To remove Polyseal from Gland Assembly, remove the Gland Assembly Retaining Ring and Spacer first.

Caution: A plastic or wooden drift must be used to avoid damaging the handle bore.

26. Push Intensifier Piston (Fig. 4) out of handle. Push out from top to bottom.

27. To service handle sleeve and handle, use a blunt-tipped punch to gently tap sleeve from top of handle through the bottom. Inspect sleeve for damage or wear, and replace if necessary. Service O-ring inside handle bore.

ASSEMBLY



Clean components with mineral spirits or similar solvent. Inspect for wear/damage and replace as necessary. Replace all seals of disassembled components. Use O-rings, Quad rings and Back-up rings in Service Parts Kit, P/N 256KIT. Smear LUBRIPLATE 130AA or PARKER-O-LUBE on O-rings, Quad rings, Back-up rings and mating parts to ease assembly. Assemble tool taking care not to damage O-rings, Quad rings, or Back-up rings.

1. Holding handle inverted in a vice, install O-ring inside handle. Align small slot in handle sleeve with timing pin hole inside handle and press in until seated.
2. Place air cylinder on handle with timing pin positioned in matching hole. Assemble Gland Assembly 127326 (Fig. 11), screw it into the handle, and torque to 75-85 foot lbs. using 1 3/8 socket wrench.
3. Push air piston/rod assembly, with O-ring in place, into air cylinder until it seated inside of air cylinder.

4. Turn tool upright. Install Intensifier Piston, with O-Ring and Back-up Rings in place, into handle. Carefully, without damaging seals, press in from top of handle. (Fig. 4)

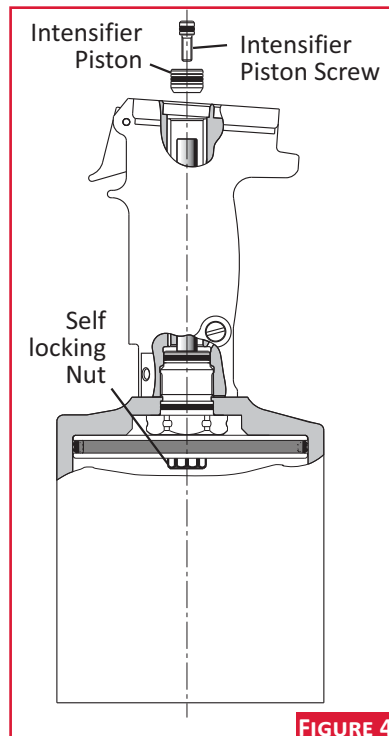


FIGURE 4

5. Push Intensifier Piston Screw, with O-Ring in place, through Intensifier Piston, and screw into top of Piston Rod. Hold Self-locking Nut with 9/16 socket and extension and torque Screw using 7/64 hex key to 55 - 60 in. lbs.
6. (Fig. 3) Hold handle in vise with bottom up. Push Cylinder Head, with O-Ring in place, squarely into air cylinder. Install Retaining Ring.
7. (Fig. 3) Position O-Ring and Muffler on center of air cylinder. Place Bottom Exhaust Gasket on air cylinder. **NOTE: Orient lip of gasket as shown in Figure 3.** Place Muffler End Cap on top of Gasket, and secure with 3 Button Head Screws using 1/8 hex key.
8. Turn tool upright. (Fig. 11) Drop Throttle Valve Spring into Throttle Valve hole in cylinder. Push Throttle Valve, with O-rings in place, into cylinder.
9. (Fig. 10) Assemble Trigger, Cable, and Cable Pin, and slide Cable into Handle. Align hole in Trigger with hole in Handle and install Trigger Pin with a hammer and punch.
10. (Fig. 11) Slide Throttle Arm onto ball end of throttle cable. Swing arm until other end fits over throttle valve. Attach

Throttle Arm Bushing and Screw to Throttle Arm, and tighten with 5/32 hex key.

11. If air hose assembly was removed, reinstall it.
12. (Figs. 1 & 10) If Relief Valve Seat Assy is being replaced, push Plug "A", with O-Ring and Back-up Ring in place, into head. Install Screw "B".
13. Carefully drive Relief Valve Seat Assy in using a soft drift, without damaging Relief Valve Ball surface.
14. (Fig. 10) Assemble Pull Piston with new seals. Lubricate with LUBRIPLATE or PARKER SUPER-O-LUBE.
15. (Fig. 2) Thread Assembly Bullet onto Pull Piston Assy. **NOTE: Spacer not needed during assembly. Its purpose is to push out the front gland during disassembly.**
16. (Fig. 2) Push Front Gland Assy, with all seals, Housing, and Wiper in place, over Assembly Bullet and onto Pull Piston. Push entire gland and piston assembly into Head.
17. (Fig. 10) Install O-Rings and Back-up Rings on Rear Gland and push complete assembly into Head. Screw in Cylinder Cap and tighten.
18. (Fig. 10) Install O-ring & Back-up Ring on Relief Valve Plug; then install Ball, Ball Guide, Sleeve, Spring, and assembled Relief Valve Plug into head.
19. Install O-Ring on Check Valve Bleed Plug "D", then install Ball, Guide, Spring, and assembled Check Valve Plug into head.
20. Push Pintail Deflector onto barbed end of Pull Piston.
21. (Figs. 1, 9, & 10) Place O-Rings on Bleed Plugs "C" & "E" and screw assemblies into Handle (Qty. 1) and Cylinder Head (Qty. 2).
22. (Figs. 5 & 10) Install all O-Rings and Back-up Rings on Pull and Return Glands. Push Gland Assemblies into handle. Push Head down on glands.
23. Place tool in a vise, head down, and install 4 Cap Screws, and torque to 170 inch pounds. (Fig. 5)
24. Tool is now assembled and ready for Fill & Bleed.

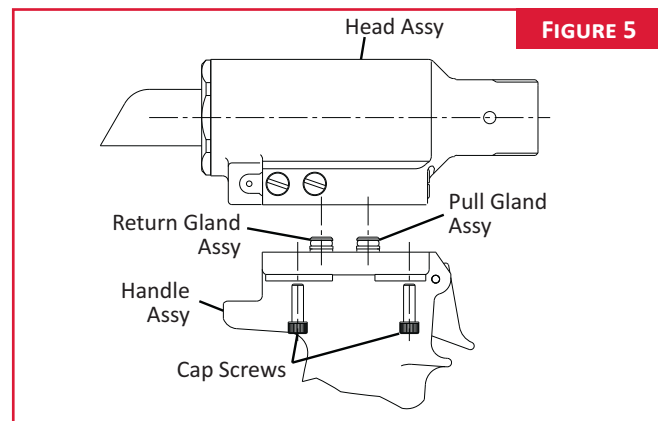


FIGURE 5



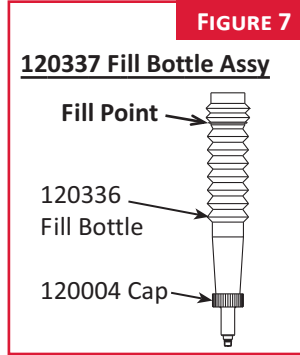
FILL AND BLEED

Equipment Required:

- Shop airline 90-100 psi max.
- Air regulator
- Fill Bottle (Fig. 7, supplied with tool)
- Fill Tool 112465
- Large flat blade screwdriver
- Stall Nut 120824
- Nose assembly
- Fasteners (Optional)

Preparation:

1. Install air regulator in airline, and set pressure to 20-40 psi.
2. Fill bottle almost full of DEXRON III - ATF (automatic transmission fluid). **NOTE: Refill tool only when red line on plunger drops below the red line on the reservoir housing or when tool is rebuilt.**

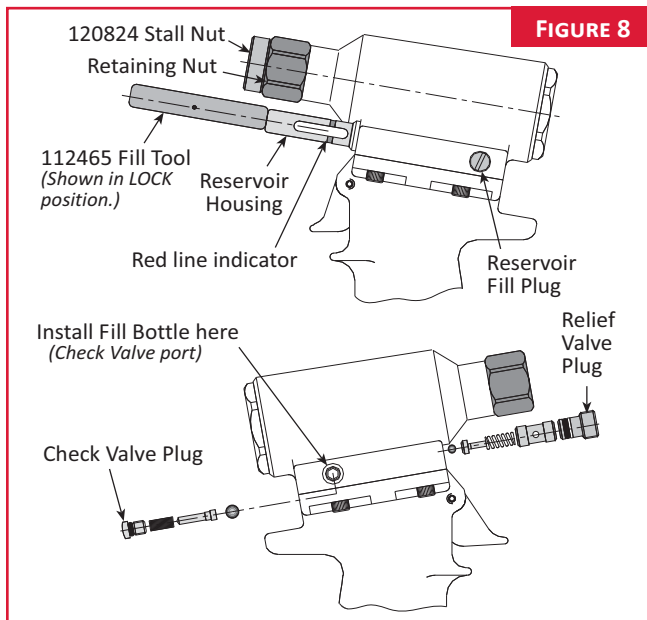


WARNING: Avoid contact with hydraulic fluid. Hydraulic fluid must be disposed of in accordance with Federal, State and Local Regulations.

FOR PARTS IDENTIFICATION, SEE FIGURES 10 AND 11.

STEP 1: Screw Fill Tool into Reservoir Plunger, pull Plunger into Reservoir Housing and lock Fill Tool in full forward position by tilting handle (long side touching tool) and locking in place. (Figure 8)

STEP 2: Remove Relief and Check Valve Plugs, Guides, Springs and Balls from ports in head. Reinstall Plug and Sleeve in head in Relief Valve port (front of tool).

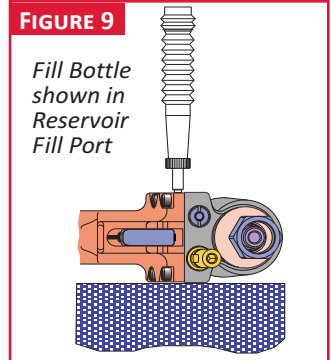


STEP 3: Screw retaining nut onto Head Assembly. Screw Stall Nut onto Hydraulic Piston and tighten to ensure full thread engagement. Back off Retaining Nut until it engages Stall Nut. Check that Hydraulic Piston is all the way forward and locked with Retaining Nut and with (or without) Stall Nut.

STEP 4: Attach the tool air source momentarily to seat Air Piston at bottom of Air Cylinder, then disconnect tool. With Reservoir Fill port facing up, lay tool on its side.

STEP 5: Install Fill Bottle in Reservoir Fill port. (Figure 9)

STEP 6: Connect tool to shop air 20 to 40 psi. Cycle tool 20-30 times, watch for air bubbles escaping from the tool into bottle. (You may rock the tool to free trapped air in the tool.) Do not allow the air to re-enter the tool. When cycling tool, always hold bottle up as shown in Figure 10 to prevent drawing in air from empty part of bottle.



WARNING: Air pressure MUST be set to 20 to 40 psi to prevent possible injury from high pressure spray. If Check Valve Plug is removed, Fill Bottle must be in place before cycling tool.

STEP 7: When air bubbles no longer appear in bottle, remove Fill Bottle and replace the Reservoir Fill Plug while tool is lying on its side.

STEP 8: Install the Check Valve Ball, Guide and Spring. Replace the Check Valve Plug.

STEP 9: Turn tool so front of head faces you. Prior to removing Relief Valve Plug, using a 3/32 Allen wrench, back out setscrew inside of the plug approximately 1/2 turn counterclockwise. This ensures that the Piston will remain in full-forward position. Remove the Relief Valve Plug, install Ball, Guide, Sleeve and Spring, and replace the plug.

STEP 10: Unlock Fill Tool and check Reservoir red line. Cycle the tool the with Stall Nut attached and Retaining Nut locked in the full-forward position ("Dead Stall"). Reservoir should not drop below the red line on the Reservoir housing.

STEP 11: Re-lock the fill tool. Lay tool on its side and remove Reservoir Fill Plug. Top off Reservoir by placing a few drops of oil in hole and waiting for air bubbles to escape. Push a pin or a scribe into hole to check for trapped air bubbles. Replace Plug.



WARNING: Failure to re-lock Fill Tool will result in oil being ejected from the head under pressure during the topping off of the Reservoir. Severe personal injury may result.

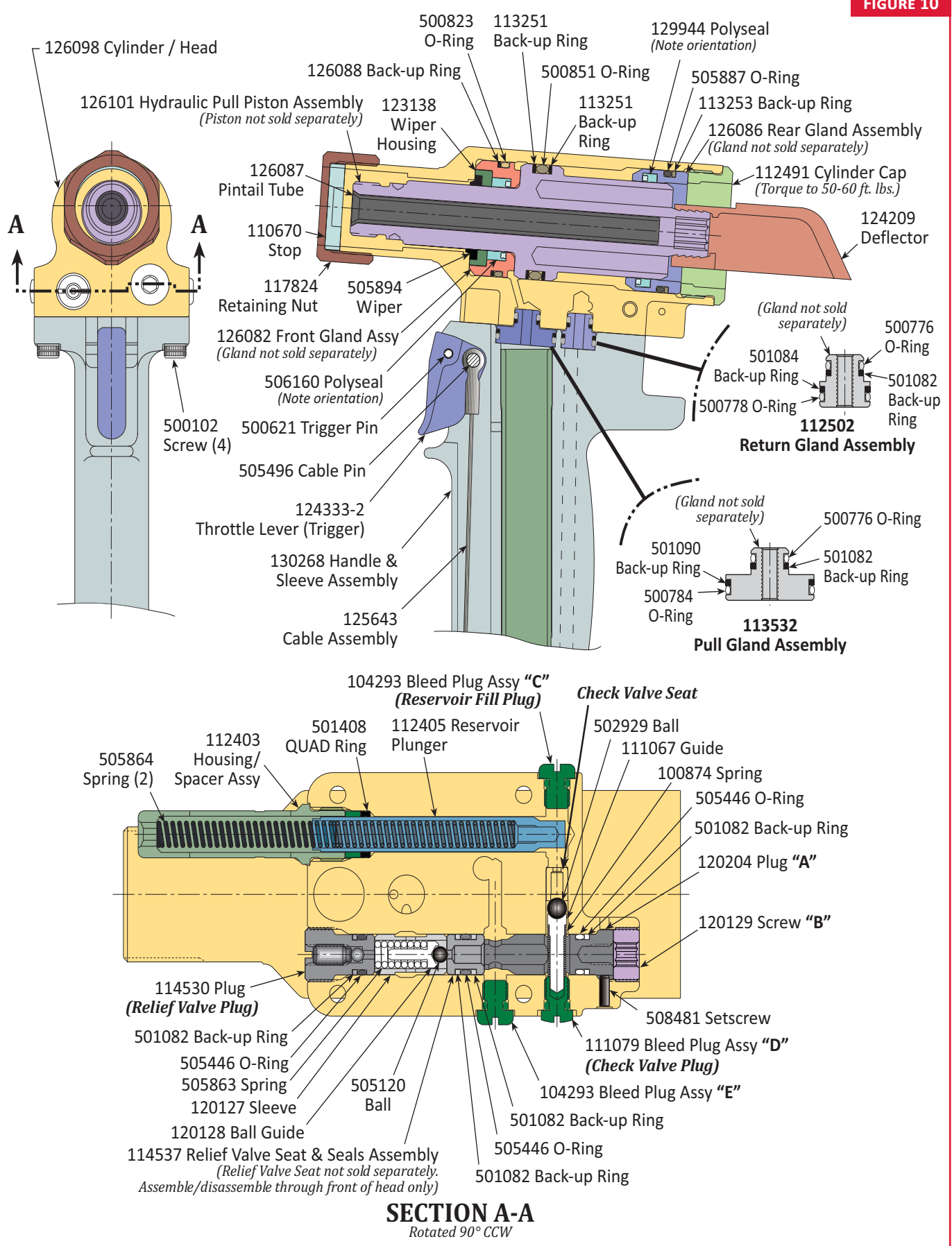
STEP 12: Unlock the Fill Tool and cycle tool as in step 10. Reservoir may drop slightly. If so, repeat step 11 until, when the Fill Tool handle is touched, it has no pressure against it and it drops out of the lock position, and the Reservoir Plunger does not drop when tool is cycled. **NOTE: This usually requires 3 to 4 times topping off.**

STEP 13: Remove Fill Tool and Stall Nut. Install a nose assembly and pull several fasteners to test function.

HEAD/HANDLE COMPONENTS

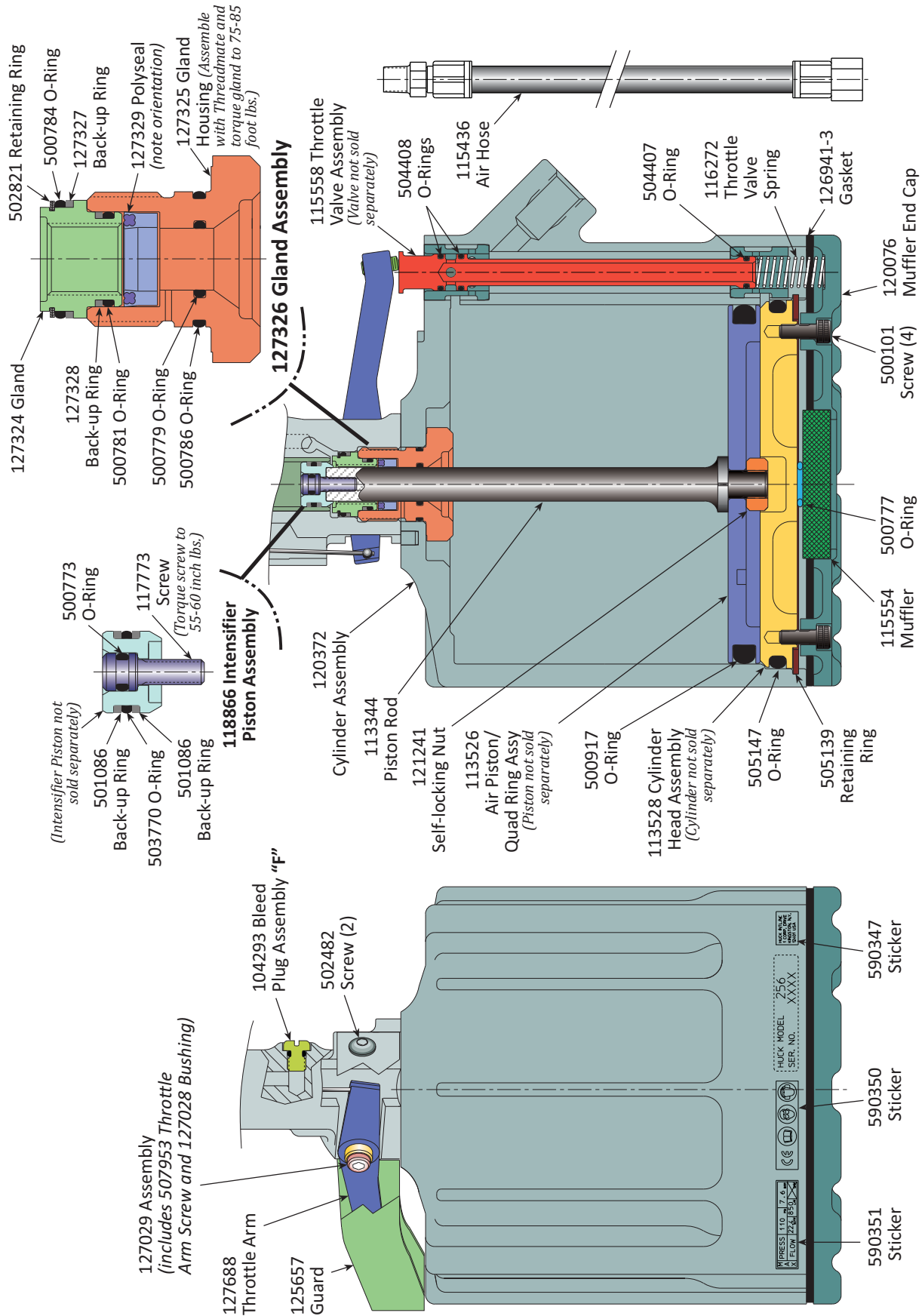


FIGURE 10



AIR CYLINDER COMPONENTS

FIGURE 11



TROUBLESHOOTING



Always check out the simplest possible cause of a malfunction first. For example, an air hose not connected. Then proceed logically, eliminating each possible cause until the cause is located. Where possible, substitute known good parts for suspected bad parts. Use TROUBLESHOOTING CHART as an aid in locating and correcting malfunction.

Note: “Piston drift” is when the air piston is in the down position, but the hydraulic pull piston is not in the full forward position. This causes an out of sequence condition.

- 1 Tool fails to operate when trigger is depressed.
 - a) Air line not connected
 - b) Throttle Valve O-rings worn or damaged.
 - c) Throttle Valve Cable is broken.
- 2 Tool does not complete fastener installation and break pintail.
 - a) Air pressure too low
 - b) Air Piston Quad Ring worn or damaged.
 - c) Reservoir empty or low, refer to Fill and Bleed section.
 - d) Air in hydraulic system, refer to Fill and Bleed section.
 - e) Reservoir Springs worn or damaged
 - f) Check for piston drift
- 3 Pintail stripped and/or swaged collar not ejected.
 - a) Check for broken or worn jaws in nose assembly, refer to nose assembly data sheet.
 - b) Check for loose Retaining Nut
 - c) Check for piston drift.
- 4 Tool has piston drift.
 - a) Loose collet crashing into the front of the anvil causes the relief valve to open allowing the piston to drift. Tighten the collet and refer to Fill and Bleed section.
 - b) Worn or damaged Return Pressure Relief Valve in tool, inspect Seat, O-Ring, Back-up Rings, Steel Ball and Valve Spring. Replace if necessary.
 - c) Worn or damaged Intensifier Piston Assembly: Inspect O-Rings and Back-up Rings, and replace if necessary.
- 5 Hydraulic fluid exhausts with air or leaks at base of handle.
 - a) Worn or damaged Gland Assembly: Inspect Polyseal, O-rings, Quad Ring, and Back-up Ring, and replace if necessary.
6. Hydraulic fluid leaks at rear of Pull Piston
 - a) Worn or damaged Rear Gland: Inspect O-Rings and Back-up Rings, and replace if necessary.
7. Hydraulic fluid leaks at front of Pull Piston.
 - a) Worn or damaged Front Gland: Inspect Polyseal and replace if necessary.
8. Pull Piston will not return.
 - a) Throttle Valve stuck: Lubricate O-Rings.
 - b) Throttle Arm, Cable, or Trigger binding.
9. Air leaks at Air Cylinder Head.
 - a) Worn or damaged O-Ring. Replace if necessary.

ACCESSORIES



Stroke Limiter	-	118362-1
<i>Reduces stroke to .750 inches (1.91 cm)</i>		
Stall Nut	-	120824
Pintail Collection Bag	-	125655
Service Tool Kit	-	126104
<i>Includes:</i>		
<i>Piston Assembly Bullet (Fig. 2)</i>	-	<i>123111-1</i>
<i>Spacer (Fig. 2)</i>	-	<i>123112-1</i>



LIMITED WARRANTIES

TOOLING WARRANTY:

Huck warrants that tooling and other items (excluding fasteners, and hereinafter referred as "other items") manufactured by Huck shall be free from defects in workmanship and materials for a period of ninety (90) days from the date of original purchase.

WARRANTY ON "NON-STANDARD OR CUSTOM MANUFACTURED PRODUCTS":

With regard to non-standard products or custom manufactured products to customer's specifications, Huck warrants for a period of ninety (90) days from the date of purchase that such products shall meet Buyer's specifications, be free of defects in workmanship and materials. Such warranty shall not be effective with respect to non-standard or custom products manufactured using buyer-supplied molds, material, tooling and fixtures that are not in good condition or repair and suitable for their intended purpose.

THERE ARE NO WARRANTIES WHICH EXTEND BEYOND THE DESCRIPTION ON THE FACE HEREOF. HUCK MAKES NO OTHER WARRANTIES AND EXPRESSLY DISCLAIMS ANY OTHER WARRANTIES, INCLUDING IMPLIED WARRANTIES AS TO MERCHANTABILITY OR AS TO THE FITNESS OF THE TOOLING, OTHER ITEMS, NON-STANDARD OR CUSTOM MANUFACTURED PRODUCTS FOR ANY PARTICULAR PURPOSE AND HUCK SHALL NOT BE LIABLE FOR ANY LOSS OR DAMAGE, DIRECTLY OR INDIRECTLY, ARISING FROM THE USE OF SUCH TOOLING, OTHER ITEMS, NONSTANDARD OR CUSTOM MANUFACTURED PRODUCTS OR BREACH OF WARRANTY OR FOR ANY CLAIM FOR INCIDENTAL OR CONSEQUENTIAL DAMAGES.

Huck's sole liability and Buyer's exclusive remedy for any breach of warranty shall be limited, at Huck's option, to replacement or repair, at FOB Huck's plant, of Huck manufactured tooling, other items, nonstandard or custom products found to be defective in specifications, workmanship and materials not otherwise the direct or indirect cause of Buyer supplied molds, material, tooling or fixtures. Buyer shall give Huck written notice of claims for defects within the ninety (90) day warranty period for tooling, other items, nonstandard or custom products described above and Huck shall inspect products for which such claim is made.

TOOLING, PART(S) AND OTHER ITEMS NOT MANUFACTURED BY HUCK:

HUCK MAKES NO WARRANTY WITH RESPECT TO THE TOOLING, PART(S) OR OTHER ITEMS MANUFACTURED BY THIRD PARTIES. HUCK EXPRESSLY DISCLAIMS ANY

WARRANTY EXPRESSED OR IMPLIED, AS TO THE CONDITION, DESIGN, OPERATION, MERCHANTABILITY OR FITNESS FOR USE OF ANY TOOL, PART(S), OR OTHER ITEMS THEREOF NOT MANUFACTURED BY HUCK. HUCK SHALL NOT BE LIABLE FOR ANY LOSS OR DAMAGE, DIRECTLY OR INDIRECTLY, ARISING FROM THE USE OF SUCH TOOLING, PART(S) OR OTHER ITEMS OR BREACH OF WARRANTY OR FOR ANY CLAIM FOR INCIDENTAL OR CONSEQUENTIAL DAMAGES.

The only warranties made with respect to such tool, part(s) or other items thereof are those made by the manufacturer thereof and Huck agrees to cooperate with Buyer in enforcing such warranties when such action is necessary.

Huck shall not be liable for any loss or damage resulting from delays or nonfulfillment of orders owing to strikes, fires, accidents, transportation companies or for any reason or reasons beyond the control of the Huck or its suppliers.

HUCK INSTALLATION EQUIPMENT:

Huck International, Inc. reserves the right to make changes in specifications and design and to discontinue models without notice.

Huck Installation Equipment should be serviced by trained service technicians only.

Always give the Serial Number of the equipment when corresponding or ordering service parts.

Complete repair facilities are maintained by Huck International, Inc. Please contact one of the offices listed below.

Eastern

One Corporate Drive Kingston, New York 12401-0250
Telephone (845) 331-7300 FAX (845) 334-7333

Outside USA and Canada

Contact your nearest Huck International Office, see back cover.

In addition to the above repair facilities, there are Authorized Tool Service Centers (ATSC's) located throughout the United States. These service centers offer repair services, spare parts, Service Parts Kits, Service Tools Kits and Nose Assemblies. Please contact your Huck Representative or the nearest Huck office listed on the back cover for the ATSC in your area.

Alcoa Fastening Systems & Rings



About Alcoa Fastening Systems & Rings, a business unit of Alcoa, is a leading worldwide designer and manufacturer of fastening systems and rings, including specialty fasteners, fluid fittings, assembly components, installation systems, and seamless rings for aerospace

and industrial applications. Headquartered in Torrance, California, the company has over 8,300 employees at 39 manufacturing and distribution/logistics locations in 13 countries. For more information, visit afsr.alcoa.com

Alcoa Fastening Systems & Rings world-wide locations:

AMERICAS

**Alcoa Fastening Systems & Rings
Aerospace Fasteners Division**
3724 East Columbia
Tucson, AZ 85714
800-234-4825
520-747-9898
FAX: 520-748-2142

**Alcoa Fastening Systems & Rings
Aerospace Fasteners Division**
PO Box 5268
900 Watson Center Rd.
Carson, CA 90749
800-421-1459
310-830-8200
FAX: 310-830-1436

**Alcoa Fastening Systems & Rings
Industrial Fasteners Division**
PO Box 8117
8001 Imperial Drive
Waco, TX 76714-8117
800-388-4825
254-776-2000
FAX: 254-751-5259

**Alcoa Fastening Systems & Rings
Fasteners Division**
1 Corporate Drive
Kingston, NY 12401
800-278-4825
845-331-7300
FAX: 845-334-7333

**Alcoa Fastening Systems & Rings
Industrial Products
Latin America Operations**
Avenida Parque Lira. 79-402
Tacubaya Mexico, D.F.
C.P. 11850
FAX: 525-515-1776
TELEX: 1173530 LUKSME

EUROPE

**Alcoa Fastening Systems & Rings
Industrial Products
United Kingdom Operations**
Unit C, Stafford Park 7
Telford, Shropshire
England TF3 3BQ
01952-290011
FAX: 0952-290459

**Alcoa Fastening Systems & Rings
Aerospace Products
France Operations**
Clos D'Asseville
BP4
95450 Us Par Vigny
France
33-1-30-27-9500
FAX: 33-1-34-66-0600

FAR EAST

**Alcoa Fastening Systems & Rings
Industrial Products
Australia Operations**
14 Viewtech Place
Rowville, Victoria
Australia 3178
03-764-5500
Toll Free: 008-335-030
FAX: 03-764-5510

For The Long Haul, The Future of Fastening Technology, The Future of Assembly Technology, The Future of Tooling Technology, and Tools of Productivity are service marks of Huck International. Huck provides technical assistance regarding the use and application of Huck fasteners and tooling.

NOTICE: The information contained in this publication is only for general guidance with regard to properties of the products shown

and/or the means for selecting such products, and is not intended to create any warranty, express, implied, or statutory; all warranties are contained only in Huck's written quotations, acknowledgments, and/or purchase orders. It is recommended that the user secure specific, up-to-date data and information regarding each application and/or use of such products.

HWB898 1003-5M



For the Long Haul™