

Alcoa  
Fastening  
Systems



## *INSTRUCTION MANUAL*

# 256

### *PNEUDRAULIC INSTALLATION TOOL*

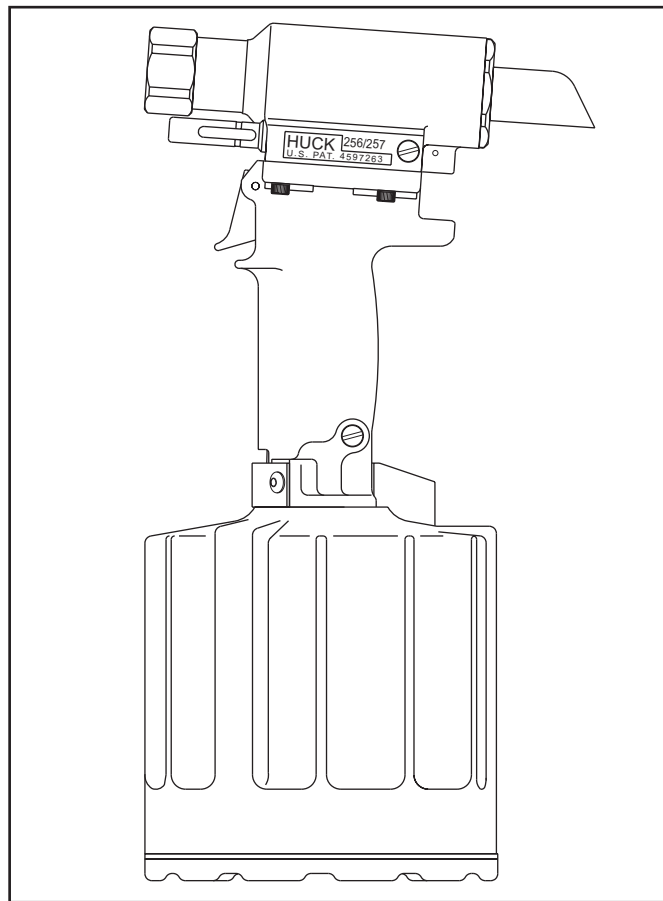

Makers of Huck®, Marson®, Recoil®  
Brand Fasteners, Tools & Accessories

08-15-2006  
HK1015



# EU Declaration of Conformity

**Manufacturer:**

Alcoa Fastening Systems, Commercial Products Division, 1 Corporate Drive, Kingston, NY, 12401, USA

**Description of Machinery:**

Model numbers **246 and 256** fastener installation tools

**Relevant provisions complied with:**

Council Directive related to Machinery, (89/392/EEC), (91/368/EEC), (93/44/EEC), (93/68/EEC)

Council Directive related to EMC/EMI, (89/336/EEC)

**European Representative:**

Rob Pattenden, Huck International, Ltd. Unit C Stafford Park 7, Telford Shropshire TF3 3BQ, England, United Kingdom

**Authorized Signature/date:**

I, the undersigned, do hereby declare that the equipment specified above conforms to the above Directive(s) and Standard(s).

Signature: \_\_\_\_\_



Full Name: Henk Rosier

Position: Engineering Manager  
Installation Systems Division

Place: Kingston, New York, USA

Date: August, 2005

## Sound Levels

**Models: 246 and 256**

SEL dB (A)	Peak Value dB (C)	Leq dB (A)
90.6	117.5	77.9

Leq reflects the equivalent noise level result of installing 1,500 typical Huck fasteners for an eight hour work day.

To calculate equivalent noise level for other quantities of fasteners in an eight hour period, use the formula:

$$\text{Leq} = \text{SEL} + 10 \log (n/28,800)$$

where **n** = number of fasteners in eight hours.

## Vibration Levels

**Models: 246 and 256**

For an eight hour work day, installing 1,500 typical Huck fasteners will result in an equivalent weighted RMS vibration level A(8) of:

$$2.5 \text{ m/s}^2$$

To calculate equivalent vibration level for other quantities of fasteners in an eight hour period, use the formula:

$$\text{Equivalent Vibration Level, A8 (m/s}^2\text{)} = (n/480) \times 0.8$$

where **n** = number of fasteners in eight hours,  
and **0.8(m/s<sup>2</sup>)** = Aeq for 60 seconds.

*Test data to support the above information is on file at Alcoa Fastening Systems, Commercial Products Division, Kingston Operations, Kingston, NY, USA. Vibration measurements are frequency weighted in accordance with ISO 8041 (1990).*

# CONTENTS

<b>EU DECLARATION OF CONFORMITY</b> .....	<b>2</b>
<b>SAFETY</b> .....	<b>4</b>
<b>SPECIFICATIONS</b> .....	<b>5</b>
<b>PRINCIPLE OF OPERATION</b> .....	<b>6</b>
<b>PREPARATION FOR USE</b> .....	<b>7</b>
<b>SERVICING THE TOOL</b>	
General .....	7
Daily .....	7
Weekly .....	7
Disassembly .....	8-9
Assembly .....	10-11
Fill and Bleed .....	12-13
Assembly Drawing .....	14
Parts List .....	15
<b>TROUBLESHOOTING</b> .....	<b>16</b>
<b>ACCESSORIES</b> .....	<b>16</b>

# SAFETY

*This instruction manual must be read with particular attention to the following safety guide lines, by any person servicing or operating this tool.*

## 1. Safety Glossary

 — Product complies with requirements set forth by the relevant European directives.

 — Read manual prior to using equipment.

 — Eye protection required while using this equipment.

 — Hearing protection required while using this equipment.



**WARNINGS - Must be understood to avoid severe personal injury.**

**CAUTIONS** - *show conditions that will damage equipment and or structure.*

**Notes** - are reminders of required procedures.

**Bold, Italic type and underlining** - emphasizes a specific instruction.

2. Huck equipment must be maintained in a safe working condition at all times and inspected on a regular basis for damage or wear. Any repair should be done by a qualified repairman trained on Huck procedures.
3. Repairman and Operator must read manual prior to using equipment and understand any Warning and Caution stickers/labels supplied with equipment before connecting equipment to any primary power supply. As applicable, each of the sections in this manual have specific safety and other information.
4. See MSDS Specifications before servicing the tool. MSDS Specifications are available from you Huck representative or on-line at [www.huck.com](http://www.huck.com). Click on Installation Systems Division.
5. When repairing or operating Huck installation equipment, always wear approved eye protection. Where applicable, refer to ANSI Z87.1 - 1989
6. Disconnect primary power source before doing maintenance on Huck equipment.
7. If any equipment shows signs of damage, wear, or leakage, do not connect it to the primary power supply.
8. Make sure proper power source is used at all times.
9. Never remove any safety guards or pintail deflector.
10. Never install a fastener in free air. Personal injury from fastener ejecting may occur.
11. When using an offset nose always clear spent pintail out of nose assembly before installing the next fastener.
12. If there is a pinch point between trigger and work piece use remote trigger. (Remote triggers are available for all tooling).
13. Do not abuse tool by dropping or using it as a hammer. Never use hydraulic or air lines as a handle. Reasonable care of installation tools by operators is an important factor in maintaining tool efficiency, eliminating downtime, and in preventing an accident which may cause severe personal injury.
14. Never place hands between nose assembly and work piece.
15. Tools with ejector rods should never be cycled with out nose assembly installed.
16. When two piece lock bolts are being used always make sure the collar orientation is correct. See fastener data sheet of correct positioning.

# TOOL SPECIFICATIONS

INCHES  
MM

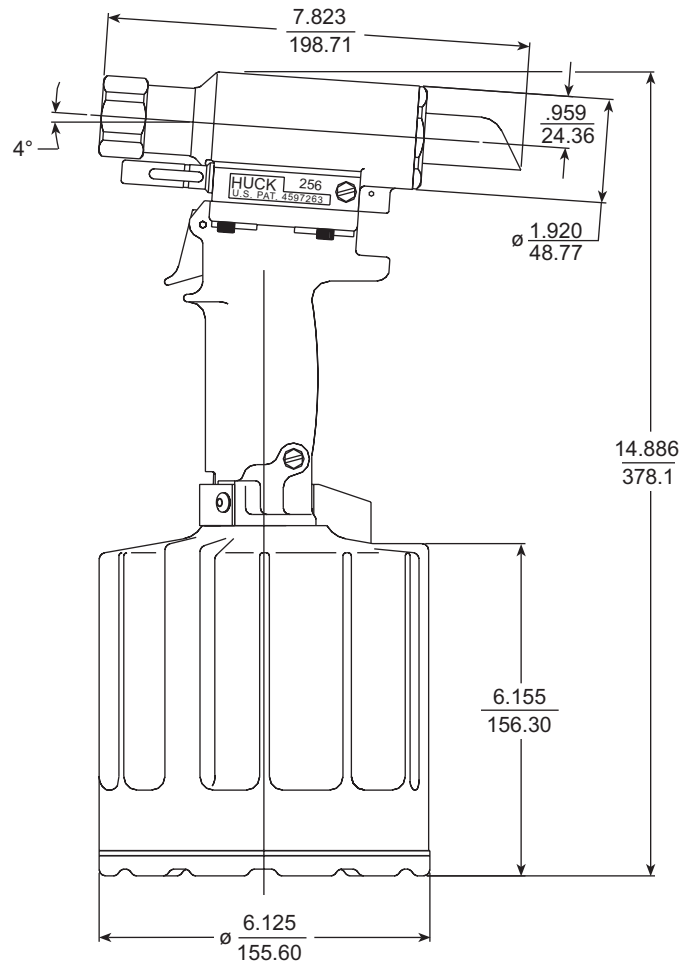
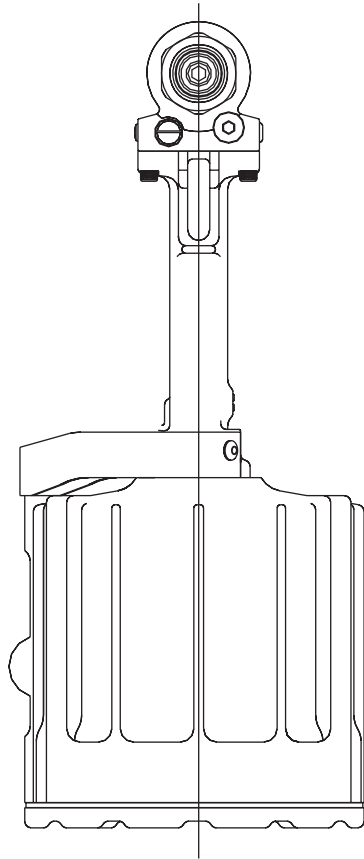

- **Stroke:** .875
- **Weight:** 11.1 lbs
- **Air Pressure:** 90-100 psi
- **Capacity:** 9986 lbs @ 90 psi
- **Speed/Cycles:** 30 per minute
- **Noise Level:** 85 dBA @ 90 psi

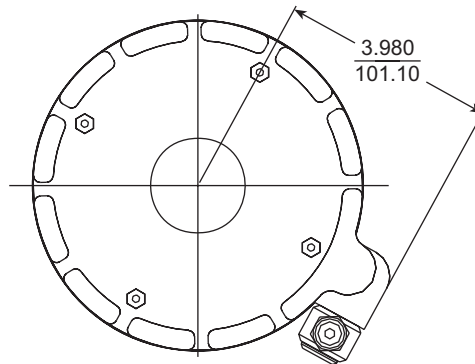

# PRINCIPLE OF OPERATION

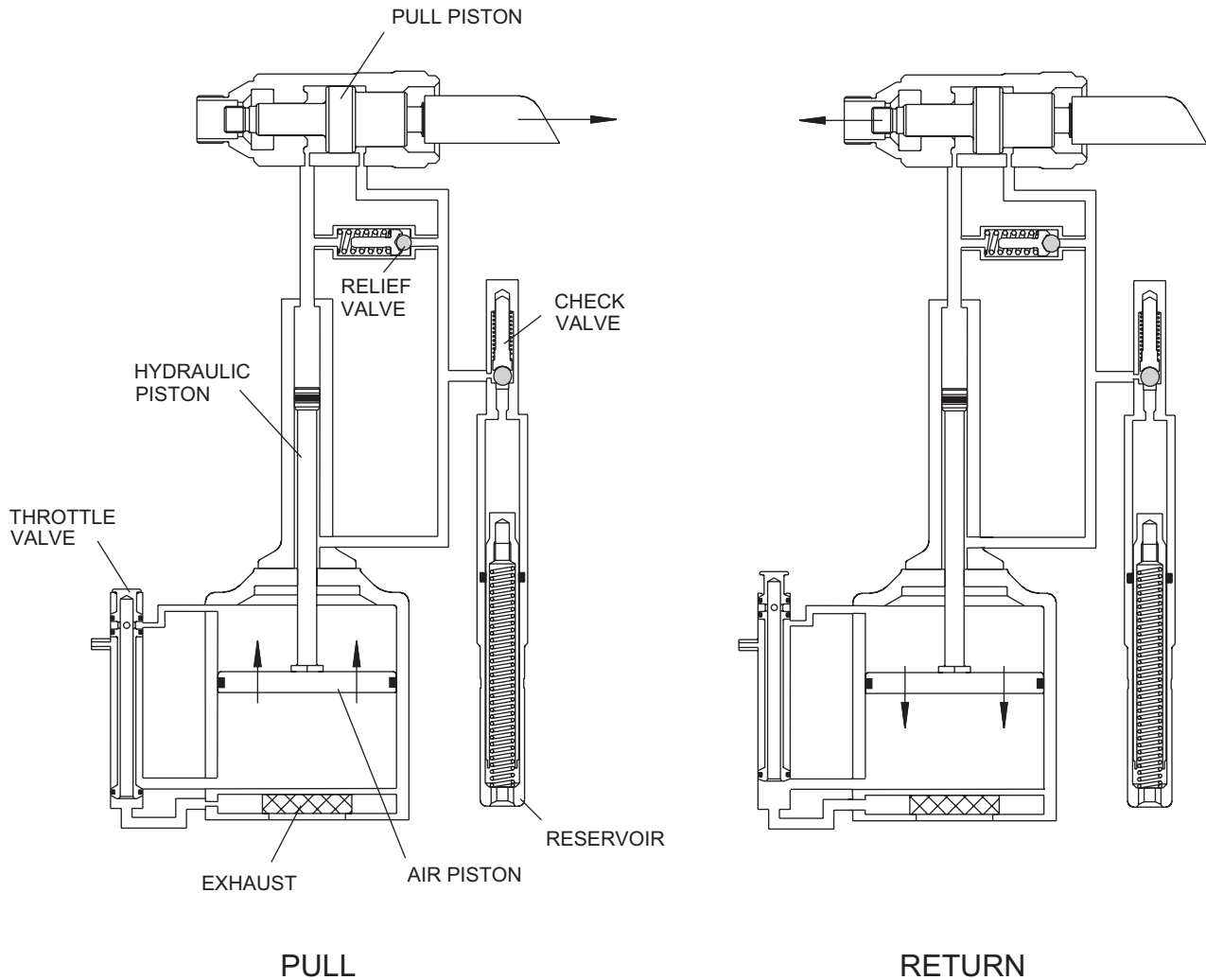

When the trigger is depressed, the throttle valve moves to down position, and pressurized air is directed to the bottom of the air piston, causing the piston to move upward. The air above the piston is exhausted and directed through the center of the throttle valve and out the bottom of the tool. The air piston has a rod and a hydraulic piston attached. When the air piston rod moves upward, a column of pressurized fluid is forced into head, which moves the pull piston back. The attached nose assembly moves with the pull piston to start fastener installation.

When fastener installation is completed, the trigger is released. Air pressure, with the assistance of a spring, causes the throttle valve to return to its up position. Pressurized air is re-directed to the top of the air piston, causing the piston to move downward. The air from below the piston is exhausted through bottom of tool. The rod and hydraulic piston move downward, hydraulic pressure is reversed and the pull piston is returned forward. Return pressure relief valve protects tool against pressure spikes. The reservoir replenishes hydraulic system as needed.

# PREPARATION FOR USE



The Model 256 Installation Tool is shipped with a plastic plug in the air inlet connector. The connector has 1/4-18 female pipe threads to accept the air hose fitting. Quick disconnect fittings and 1/4" inside diameter air hose are recommended. An air supply of 90-100 psi capable of 22.4 CFM must be available. Air supply should be equipped with a filter-regulator-lubricator unit.

1. Remove plastic shipping plug from Air Inlet Connector and put in a few drops of Automatic Transmission Fluid, DEXRON III, or equivalent.
2. Screw quick disconnect fitting into Air Inlet Connector.  
**CAUTION:** Do not use TEFLON tape on threads - - use TEFLON in stick form only. (Huck P/N 503273)
3. Set air pressure on regulator to 90-100 psi.
4. Attach optional Air Hose (38), supplied with tool, to air inlet connector.
5. Connect air hose to tool.
6. Cycle tool a few times by depressing and releasing trigger.

7. Disconnect air hose from tool.
8. Remove Retaining Nut and Stop.
9. Select proper Nose Assembly from **SELECTION CHART** for fastener to be installed.
10. Screw Collet Assembly (including lock collar and shim if applicable) onto Spindle holding Pull Piston (11) with 3/8 hex key. (Wrench Tight)
11. Slide Anvil over Collet Assembly and into counterbore.
12. Slide Stop and Retaining Nut over Anvil and screw Nut onto Head.
13. Connect air hose to tool and install fastener(s) in test plate of proper thickness with proper size holes. Inspect fastener(s).

## NOTES:

- 1 Air quick disconnect fittings and air hoses are not available from Huck International, Inc.
- 2 **VIBRA-TITE** should be used on collet threads for nose assemblies without lock collars. All other noses should be staked (*please refer to nose assembly data sheets*).

# SERVICING THE TOOL

## GENERAL

1. The efficiency and life of any tool depends upon proper maintenance. Regular inspection and correction of minor problems will keep tool operating efficiently and prevent downtime. The tool should be serviced by personnel who are thoroughly familiar with how it operates.
2. A clean, well-lighted area should be available for servicing the tool. Special care must be taken to prevent contamination of pneumatic and hydraulic systems.
3. Proper hand tools, both standard and special, must be available.
4. All parts must be handled carefully and examined for damage or wear. Always replace Seals, when tool is disassembled for any reason. Components should be disassembled and assembled in a straight line without bending, cocking, or undue force. Disassembly and assembly procedures outlined in this manual should be followed.
5. **Service Parts Kit 256KIT** includes consumable parts and should be available at all times. Other components, as experience dictates, should also be available.



**WARNING: Inspect tool for damage or wear before each use. Do not operate if damaged or worn, as severe personal injury may occur.**

## DAILY

1. If a Filter-Regulator-Lubricator unit is not being used, uncouple air disconnects and put a few drops of Automatic Transmission Fluid or light oil into the air inlet of the tool. If the tool is in continuous use, put a few drops of oil in every two to three hours.
2. Bleed the air line to clear it of accumulated dirt or water before connecting air hose to the tool.
3. Check all hoses and couplings for damage or air leaks, tighten or replace if necessary.
4. Check the tool for damage or air/hydraulic leaks, tighten or replace if necessary.
5. Check the nose assembly for tightness or damage, tighten or replace if necessary.
6. Check oil level in tool reservoir, replenish if necessary.

## WEEKLY

1. Disassemble and clean nose assemblies and reassemble per applicable NOSE ASSEMBLY DATA SHEET.
2. Check the tool and all connecting parts for damage or oil/air leaks, tighten or replace if necessary.

# MODEL 256 DISASSEMBLY INSTRUCTIONS



**WARNING:** Be sure air hose is disconnected from tool before cleaning, or performing maintenance. Severe personal injury may occur if air hose is not disconnected.

For component identification and Parts list, refer to Figures 1 thru 4 and 9. **NOTE:** The following procedure is for complete disassembly of tool. Disassemble **only** components necessary to replace damaged O-rings, Quad rings, Back-up rings, and worn or damaged components. Always use soft jaw vice to avoid damage to tool.

1. Disconnect air hose from tool.
2. Remove nose assembly.
3. Insert Fill Tool part no. 112465 through reservoir housing and screw into Reservoir Plunger (79) locking it in the out position. (Fig. 1)
4. Unscrew Cap Screws (69) with 5/32 hex key. Carefully lift Head (89) straight up from Handle (1), remove Pull Gland (95) and Return Gland (22) from separated assemblies. Remove seals from glands. (Fig. 1)

5. Unscrew Plug (83) of return Pressure Relief Valve from front of head. Remove Spring (84), Valve Guide (86), Sleeve (85) and Steel Ball (87). A small magnet is helpful. (Fig. 1)
6. Unscrew Bleed Plug (64). Hold over waste oil container and release fill tool slowly. (Fig. 1)
7. Unscrew Reservoir Housing (81) from head. Remove two Springs (82). Slide Reservoir Plunger (79) from head. Remove spacer and Quad Ring (80). A pick may be used to remove the quad ring. (Fig. 1)
8. Unscrew Plug (71) of reservoir check valve from side of head. Remove Spring (75), check Valve Guide (76) and Stainless Steel Ball (77). (Fig. 1)
9. If check Valve Seat (78) is damaged contact your Huck representative. If Seat (88) is damaged it can be removed by using the following procedure. **NOTE:** If seat is taken out it can not be reused, it must be replaced. (Fig. 9)

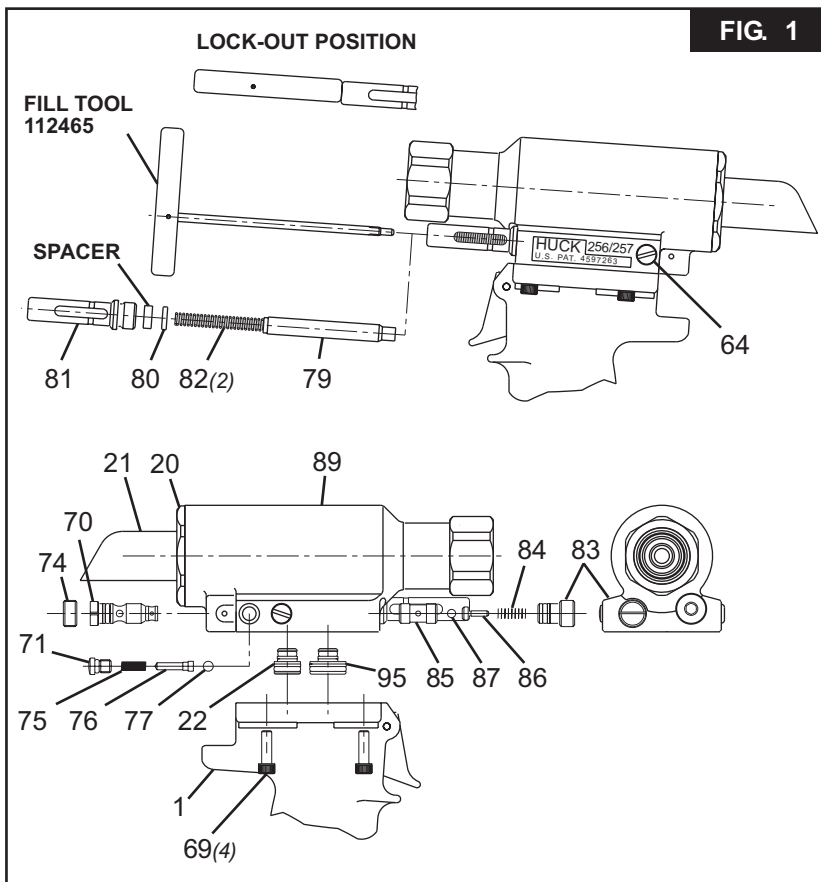

FIG. 1

10. **Seat (88) Removal:** **NOTE:** All parts in the reservoir check valve must be removed before Plug (70) can be removed. Unscrew Plug (74), insert a #10 screw in the thread of Plug (70). Pull to remove. Using a small drift and hammer, from the rear side of the head, drive Seat (88) out towards the front of the head. (Fig. 9)
11. Pintail Deflector (21) can be pulled off barbed end at rear of Pull Piston (11).
12. Unscrew End Cap (20) from Head (89) with 1 9/16 open end wrench. (Fig. 9)
13. Place Spacer (123112-1) on Pull Piston (11), and screw Assembly/Disassembly Bullet (123111-1) onto piston. Tap or press piston assembly out of head. **NOTE:** This will push out front and rear gland assemblies and wiper and wiper housing. (Fig. 2)
14. Remove Screw (67) from Throttle Arm (66). Remove throttle arm. Pull Throttle Valve (36) out of cylinder. Remove Spring (40). (Fig. 9)



DISASSEMBLY INSTRUCTIONS (CONTINUED)



15. With a small punch and hammer, drive Roll Pin (5) that retains the trigger from Handle (1). Remove Trigger Pin (4). Remove ball end of cable (2) from Throttle Arm (66), and pull cable out of handle. (Fig. 9)
16. Remove Bleed Plug (64) from handle. (Fig. 1)
17. Hold tool inverted in vice. Unscrew three Button Head Screws (45) with 1/8 hex key. (Fig. 3)
18. Remove Muffler End Cap (42), Bottom Exhaust Gasket (46), Muffler (43) and O-ring (44). (Fig. 3)
19. Remove Retaining Ring (47) from Cylinder Assembly (53). (Fig. 3) **NOTE:** Tap cylinder head down into cylinder for easier removal of retaining ring.
20. Screw Button Head Screws (45) into Cylinder Head (49). Carefully pry under screws to remove cylinder head.
21. Push air piston all the way down in cylinder and lay tool on its side. Hold Self-locking Nut (41) with a 9/16 socket and extension and, with 7/64 hex key, remove piston Screw (32). (Fig. 4 & 9)
22. Turn cylinder and handle upside down and secure in a vise.
23. Grip Self-locking Nut (41) under Air Piston (51) with pliers and pull piston and rod assembly from handle and cylinder assembly. (Fig. 3 & 4) **CAUTION:** Care must be taken not to scratch piston rod or cylinder during removal.

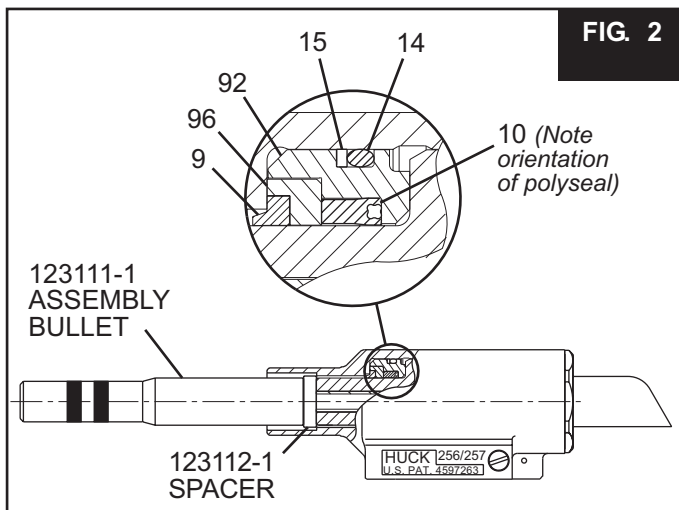
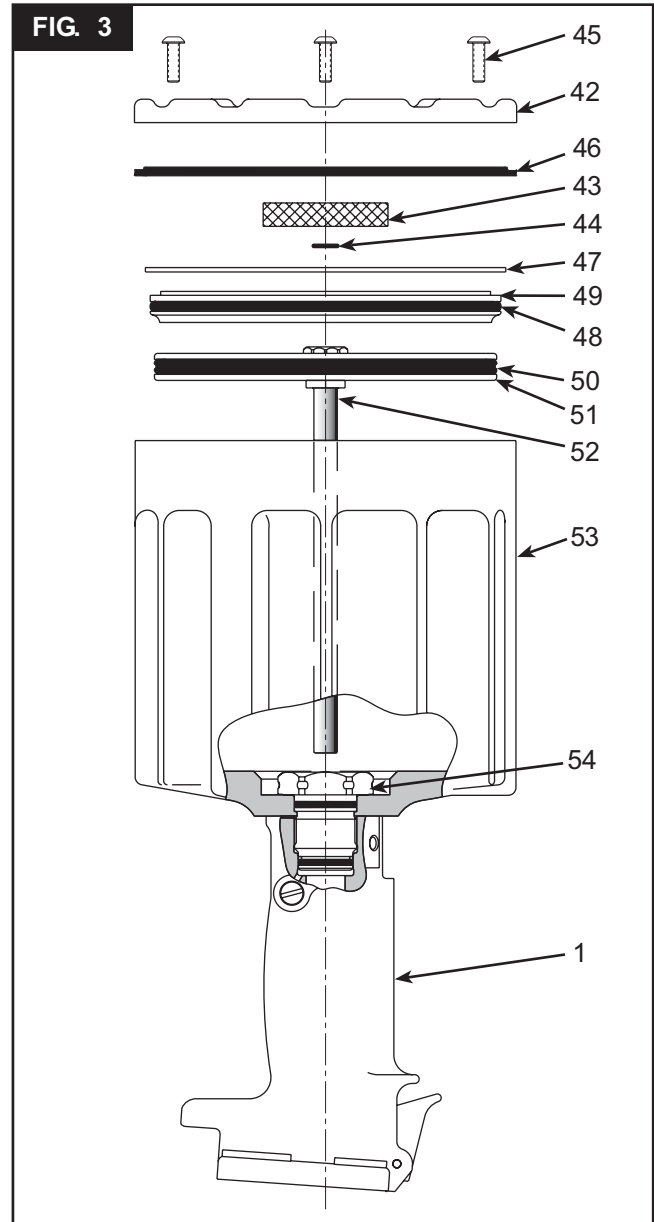

24. With a 1 3/8 socket and extension, remove Gland Assembly (54). Handle and cylinder will now separate. (Fig. 3)
25. Push Hydraulic Piston (31) out of handle. Push out from top to bottom. **CAUTION:** A plastic or wooden drift must be used to avoid damaging the handle bore.
26. To remove Variseal (61) from Gland Assembly (54). Remove Retaining Ring (59) and Spacer (60). (Fig. 9)

## MODEL 256 ASSEMBLY INSTRUCTIONS



(Refer to Figures 1 thru 5 and 9.)

Clean components with mineral spirits, or similar solvent. Inspect for wear/damage and replace as necessary. Replace all seals of disassembled components. Use O-rings, Quad rings and Back-up rings in **Service Parts Kit, P/N 256KIT**. Smear LUBRIPLATE 130AA or PARKER-O-LUBE on O-rings, Quad rings, Back-up rings and mating parts to ease assembly. Assemble tool taking care not to damage O-rings, Quad rings, or Back-up rings.

1. Holding handle inverted in a vice, Place Cylinder (53) on handle with Timing Pin positioned in matching hole. Assemble Gland Assembly (54). (Fig. 9) Screw complete gland assembly into handle. Torque to 100 - 120 ft. lbs. using 1 3/8 socket wrench.
2. Push Air Piston/Rod assembly with Quad Ring (50) in place into air cylinder until it bottoms at top of cylinder. (Fig. 3)
3. Turn tool upright. Install Hydraulic Piston Assembly (31) (with O-ring (33) and Back-up Rings (93) in place) in handle. Press in from top of handle taking care not to damage seals. (Fig. 4)

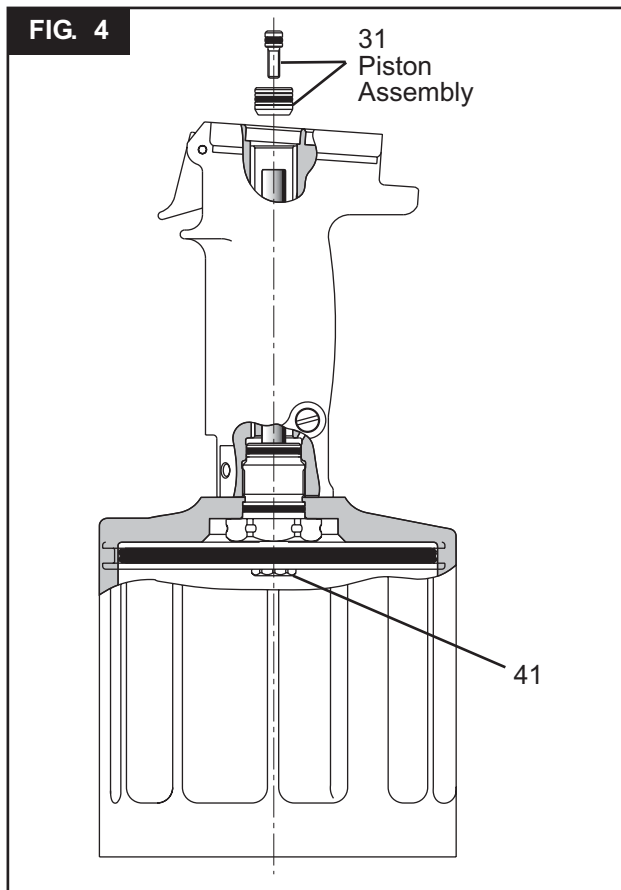

4. Push Screw (32) with O-ring (35) in place through Hydraulic Piston (34) and screw into top of piston rod. Hold Nut (41) with 9/16 socket and extension and torque Screw (32) using 7/64 hex key to 55 - 60 in. lbs.
5. Hold handle in vise with bottom facing up. Push Cylinder Head (49) with O-ring (48) in place squarely into cylinder. Install Retaining Ring (47). (Fig. 3 & 9)
6. Position O-ring (44) and Muffler (43) on center of Cylinder Head (49). Place Gasket (46) on Cylinder Assembly (53). **NOTE: Lip must face Muffler End Cap (42).** Place Muffler End Cap (42) on top of Gasket (46), and secure with 3 Button Head Screws (45) using 1/8 hex key. (Fig. 3)
7. Turn tool upright. Drop Spring (40) into Throttle valve hole in cylinder. Push Throttle Valve (36) with O-rings (37 & 39) in place into cylinder. (Fig. 9)
8. Assemble Trigger (3) Cable (2) and Trigger Pin (4), and slide cable into Handle (1). Align hole in trigger with hole in handle and install Roll Pin (5) with a hammer and punch. (Fig. 9)
9. Slide Throttle Arm (66) onto ball end of throttle cable. Swing arm until other end fits over throttle valve. Push Screw (67) through Throttle Arm (66). Tighten with 5/32 hex key.
10. If Air Hose Assembly (38) was removed, reinstall in Cylinder Assembly (53).
11. **{If Seat (88) is being replaced}**: Push Plug (70) (with O-ring 72 & Back-up Ring 25 in place) into head. Install Screw (74). (Fig. 9)
12. Install O-ring (72) and Back-up Rings (25) onto seat. Drive seat and seal assembly in using soft drift taking care not to damage ball seat surface. (Fig. 1 & 9)
13. Assemble Pull Piston (11) with new Seals (12 & 13). Lubricate with LUBRIPLATE or PARKER SUPER-O-LUBE. (Fig. 9)
14. Thread Assembly Bullet (123111-1) onto Pull Piston (11), and push entire assembly into head. (Fig. 2) **NOTE:** Spacer (123112-1) is not needed for this procedure.
15. Push Front Gland (92) with O-ring (14), Back-up Ring (15), Polyseal (10), Wiper Housing (96) and Wiper Seal (9) in place onto Pull Piston (11). (Fig. 2)

## ASSEMBLY INSTRUCTIONS (CONTINUED)



16. Install O-rings (16 & 18) and Back-up Rings (17 & 19) on Rear Gland (94). Push complete assembly into head, screw in End Cap (20) and tighten. (Fig. 9)
17. Install O-ring (72) & Back-up Ring (25) on Plug (83). Install Ball (87), Valve Guide (86), Sleeve (85), Spring (84) and Plug (83) into head. (Fig. 1 & 9)
18. Install O-ring (65) on Plug (71). Install Ball (77), Guide (76), Spring (75) and Plug (71) into head.
19. Push Pintail Deflector (21) onto barbed end of Pull Piston (11). (Fig. 9)
20. Place O-ring (65) on Bleed Plug (64) and screw assembly into Handle (1). (Fig. 9)
21. Install O-rings (24 & 30) & Back-up Rings (25 & 29) on Pull Gland (28). Install O-rings (24 & 26) and Back-up Rings (25 & 27) on Return Gland (23). Push Gland Assemblies (22 & 95) into handle. Push Head (89) down on glands. Place tool in a vise, head down, and install 4 Screws (69) and torque to 170 inch pounds. (Fig. 5)

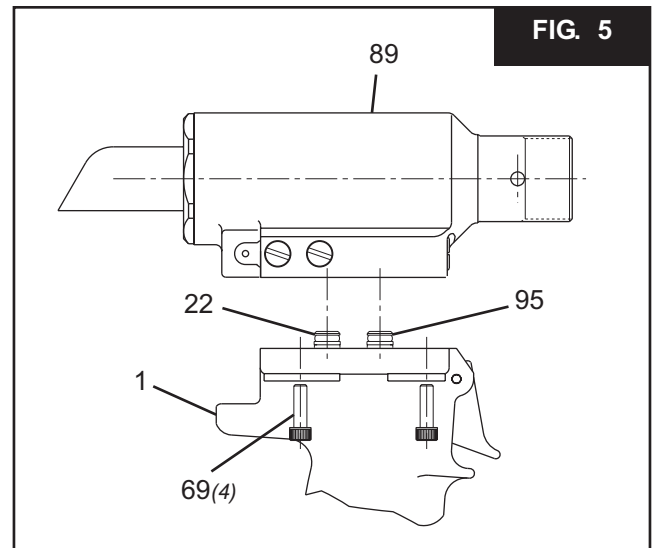

22. Tool is now completely assembled and ready for Fill & Bleed.

## SERVICE NOTES

## FILL AND BLEED INSTRUCTIONS



### Equipment Required:

- Shop airline with 90 - 100 psi max.
- Air regulator
- Fill bottle, 120337, (supplied with tool).
- Large flat blade screwdriver
- Optional Stall Nut 120824
- Nose assembly
- Fasteners (Optional)

### Preparation:

1. Install air regulator in airline and set pressure to 20-40 psi.
2. Fill bleed bottle almost full of DEXRON III - ATF or equivalent. (Fig.6)

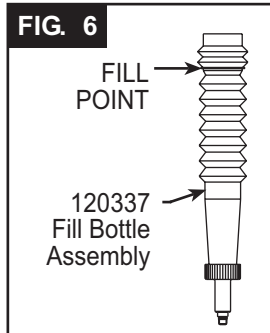

**WARNING: Avoid contact with hydraulic fluid. Hydraulic fluid must be disposed of in accordance with Federal, State and Local Regulations. Please see MSDS for Hydraulic fluid shipped with tool.**

Refill tool only when red line on plunger drops below the red line on the reservoir housing or when tool is rebuilt.

**USE: AUTOMATIC TRANSMISSION FLUID DEXRON III, OR EQUIVALENT.**

### Step 1

Screw Fill Tool P/N 112465 into Reservoir Plunger, pull Plunger into Housing and lock Fill Tool in full forward position by tilting handle (long side touching tool) and locking in place. (Fig. 7)

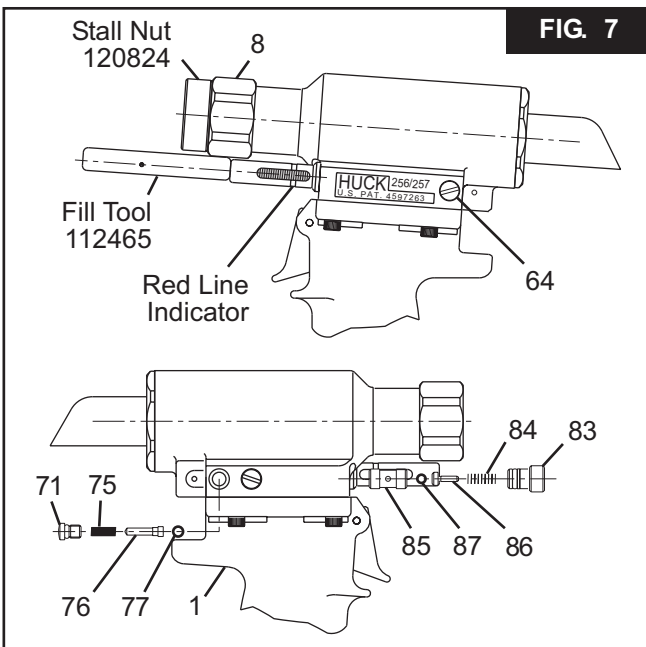

### Step 2

Remove Plugs (83) and (71) and all guides, springs and balls from ports in head. Reinstall Plug (83) in head in Relief Valve port (front of tool). (Fig. 7 & 8).

### Step 3

Screw retaining nut onto head assembly. Screw Stall Nut (optional see note:) onto Piston and tighten to ensure full thread engagement. Back off retaining nut until it engages stall nut. Check Piston location. Piston must be all the way forward and locked with stall nut and retaining nut. **Note: If Stall Nut is not used, piston must be pushed to the full forward position before installing valves.**

### Step 4

Attach the tool air source momentarily to seat air piston at bottom of cylinder. Disconnect tool. With fill port facing up, (check valve on side) lay tool on its side.

### Step 5

Install fill bottle in head fill port (check valve hole). (Fig. 7 & 8)

### Step 6

Connect tool to shop air regulated to 20 to 40 psi. Cycle tool 20-30 times. Watch for air bubbles escaping from the tool into bottle. (You may rock the tool to free trapped air in the tool.) Do not allow the air to re-enter the tool.



**WARNING: Air pressure MUST be set to 20 to 40 psi to prevent possible injury from high pressure spray. If plug (71) is removed, fill bottle must be in place before cycling tool.**

### Step 7

When air bubbles no longer appear in bottle, remove fill bottle while tool is lying on its side.

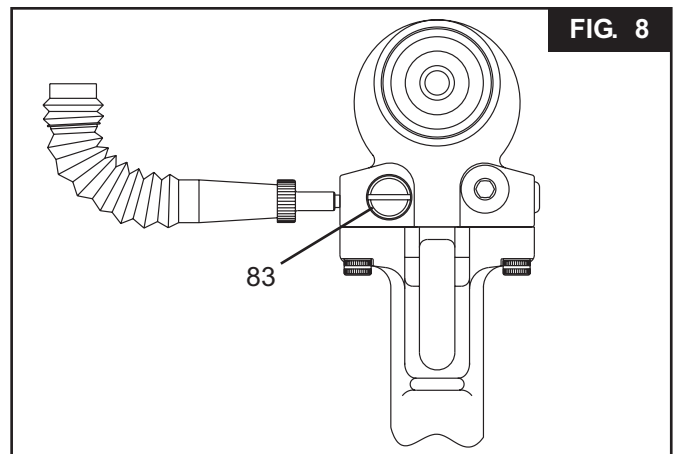

## FILL AND BLEED INSTRUCTIONS (CONTINUED)



### Step 8

Install the check valve Ball (77), Guide (76) and Spring (75). Replace the Plug (71). (Fig. 7) **Note:** *When cycling tool, always hold bottle up as shown in Figure 8 to prevent drawing in air from empty part of bottle.*

### Step 9

Turn tool so front of head faces you and remove the relief valve Plug (83). Prior to removing Plug (83), it is advisable to back out setscrew inside of plug by approximately 1/2 turn counterclockwise. (See Figure 8a). This ensures that the Piston will remain in full-forward position. Install relief valve Ball (87), Guide (86), Sleeve (85) and Spring (84). Replace the Plug (83).

FIG. 8a

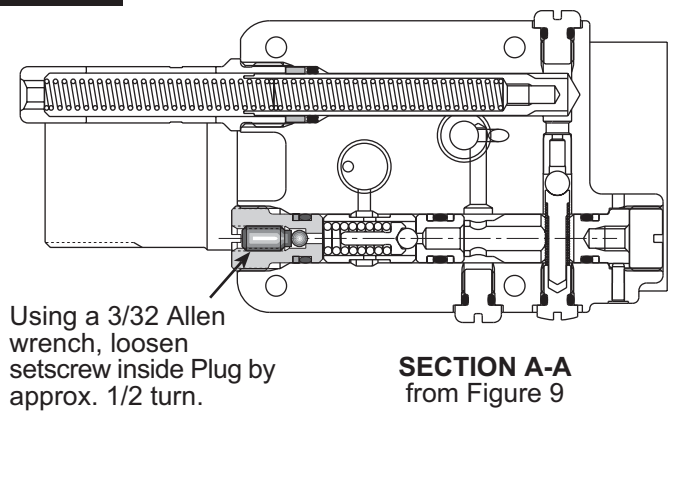

### Step 10

Unlock Fill Tool and check Reservoir red line. At this point cycle tool with Stall Nut attached (Optional. See note) and retaining nut locked in the full forward position ("Dead Stall"). Reservoir should not drop below the red line on the reservoir housing. **NOTE:** *Dead Stalling is not necessary if Optional Stall nut was not used; just cycle tool.*

### Step 11

Re-lock the fill tool in out position. Lay tool on its left side and remove Bleed Plug (64). Top off reservoir by placing a few drops of oil in hole and wait for air bubbles to escape. Push a pin or a scribe into hole to check for trapped air bubbles. Replace plug. (Fig. 7)



**WARNING - Failure to re-lock the fill tool will result in oil being ejected from the head under pressure during the topping off of the reservoir. Severe personal injury may result.**

### Step 12

Unlock the fill tool and cycle tool as in step 10. Reservoir may drop slightly. If so, repeat step 11 until, when you touch the fill tool handle, it has no pressure against it and it drops out of the lock position, and the plunger does not drop when tool is cycled. **NOTE:** This usually requires 3 to 4 times topping off.

### Step 13

Remove fill tool and stall nut (if used). Install a nose assembly and pull several fasteners to test function.

## SERVICE NOTES

FIG. 9

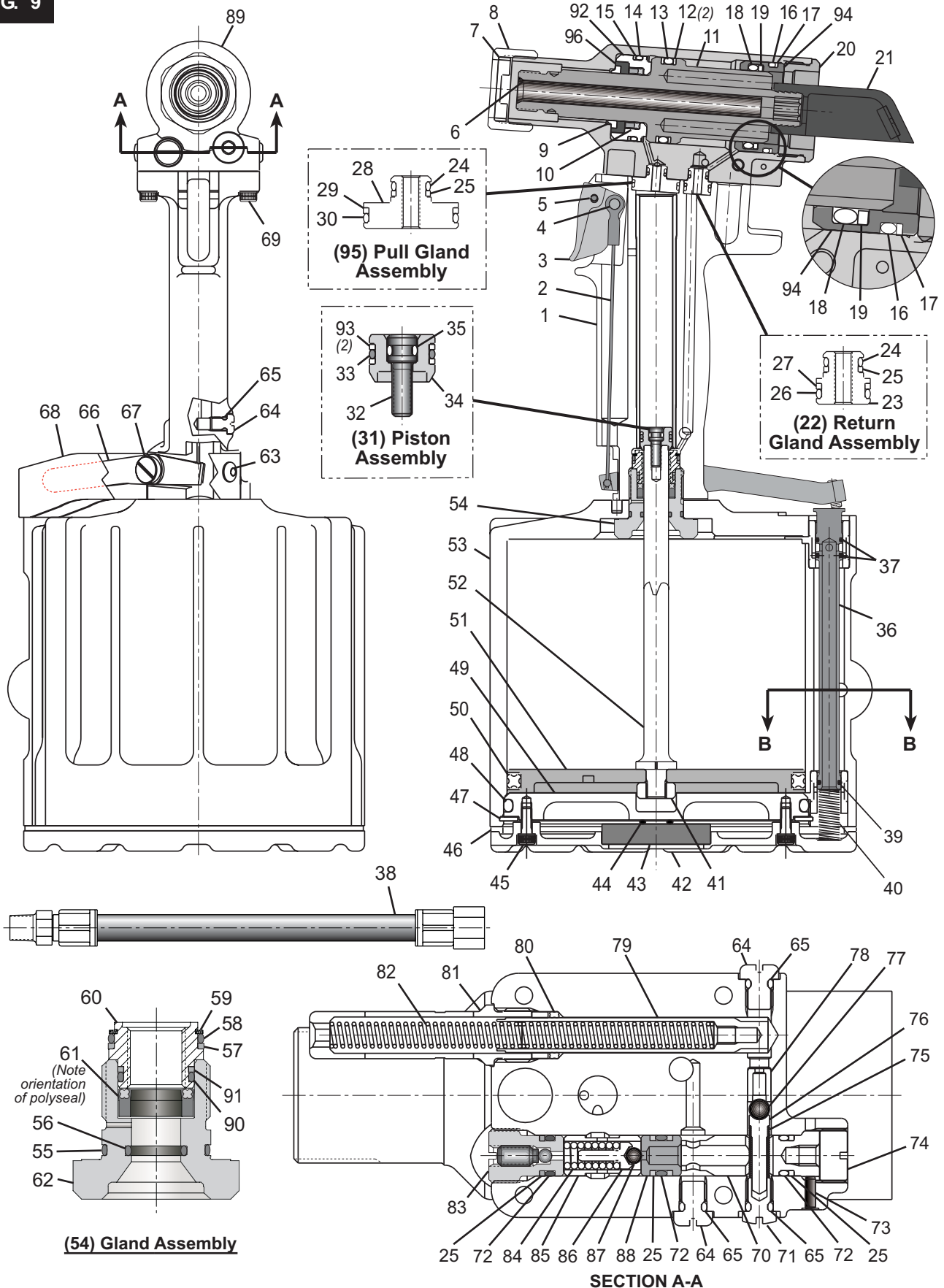



ITEM	PART#	DESCRIPTION	QTY	ITEM	PART#	DESCRIPTION	QTY
1	125642	Handle & Sleeve Assembly	1	53	120372	Cylinder Assembly	1
2	125643	Cable	1	54	127326	Gland Assembly	1
3	124333-2	Trigger	1	55	500786	O-ring	1
4	505496	Trigger Pin	1	56	500779	O-ring	1
5	500621	Roll Pin	1	57	127327	Back-up Ring	1
6	126087	Pintail Tube	1	58	500784	O-ring	1
7	110670	Stop	1	59	502821	Retaining Ring	1
8	117824	Retaining Nut	1	60	127324	Gland	1
9	505894	Wiper Seal	1	61	127329	Polyseal	1
10	506160	Polyseal	1	62	127325	Gland Housing	1
11	126100	Piston, Pull	1	63	502482	Screw	2
12	113251	Back-up Ring	2	64	100309	Bleed Plug	3
13	500851	O-ring	1	65	505438	O-ring	4
14	500823	O-ring	1	66	127688	Throttle Arm	1
15	126088	Back-up Ring	1	67	127029	Screw & Bushing Assembly	1
16	505887	O-ring	1	68	125657	Guard	1
17	113253	Back-up Ring	1	69	500102	Screw, Cap	4
18	505791	O-ring	1	70	120204	Plug	1
19	113754	Back-up Ring	1	71	111068	Plug	1
20	112491	End Cap	1	72	505446	O-ring	3
21	124211	Pintail Deflector	1	73	120203	Pin	1
22	112502	Return Gland Assembly	1	74	120129	Screw	1
23	112427	Return Gland	1	75	100874	Spring	1
24	500776	O-ring	2	76	111067	Guide	1
25	501082	Back-up Ring	6	77	502929	Ball	1
26	500778	O-ring	2	78	111139	Seat	1
27	501084	Back-up Ring	1	79	112405	Reservoir Plunger	1
28	113341	Gland	1	80	501408	Quad Ring	1
29	501090	Back-up Ring	1	81	112403	Housing/Spacer Assembly	1
30	500784	O-ring	1	82	505864	Spring	2
31	118866	Hydraulic Piston Assembly	1	83	114530	Plug	1
32	117773	Screw	1	84	505863	Spring	1
33	503770	O-ring	1	85	120127	Sleeve	1
34	117775	Hydraulic Piston	1	86	120128	Valve Guide	1
35	500773	O-ring	1	87	502506	Ball	1
36	127888	Throttle Valve	1	88	114528	Seat	1
37	504408	O-ring	2	89	126098	Head Assembly	1
38	115436	Air Hose Assembly	1	90	500781	O-ring	1
39	504407	O-ring	1	91	127328	Back-up Ring	1
40	116272	Spring	1	92	126081	Front Gland	1
41	121241	Self-locking Nut	1	93	501086	Back-up Ring	2
42	120076	Muffler End Cap	1	94	126085	Rear Gland	1
43	115554	Muffler	1	95	113532	Pull Gland Assembly	1
44	500777	O-ring	1	96	123138	Wiper Housing	1
45	500101	Screw, Button Head	4				
46	126941-3	Gasket	1				
47	505139	Retaining Ring	1				
48	505147	O-ring	1				
49	113345	Cylinder Head	1				
50	501472	Quad Ring	1				
51	113320	Piston, Air	1				
52	113344	Piston Rod	1				

# TROUBLESHOOTING



Always check out the simplest possible cause of a malfunction first. For example, an air hose not connected. Then proceed logically, eliminating each possible cause until the cause is located. Where possible, substitute known good parts for suspected bad parts. Use TROUBLESHOOTING CHART as an aid in locating and correcting malfunction.

## NOTE:

“Piston drift” is when the air piston is in the down position, but the hydraulic pull piston is not in the full forward position. This causes an out of sequence condition.

- 1 *Tool fails to operate when trigger is depressed.*
  - a) Air line not connected
  - b) Throttle Valve O-rings (37 & 39) worn or damaged.
  - c) Throttle Valve Cable (2) is broken.
- 2 *Tool does not complete fastener installation and break pintail.*
  - a) Air pressure too low
  - b) Air Piston Quad ring (50) worn or damaged.
  - c) Reservoir empty or low, refer to Fill and Bleed section.
  - d) Air in hydraulic system, refer to Fill and Bleed section.
  - e) Reservoir Springs (82) worn or damaged
  - f) Check for piston drift
- 3 *Pintail stripped and/or swaged collar not ejected.*
  - a) Check for broken or worn jaws in nose assembly, refer to nose assembly data sheet.
  - b) Check for loose Retaining Nut (8)
  - c) Check for piston drift.
- 4 *Tool has piston drift.*
  - a) Loose collet crashing into the front of the anvil causes the relief valve to open allowing the piston to drift. Tighten the collet and refer to Fill and Bleed section.
  - b) Worn or damaged Return Pressure Relief Valve in tool, inspect Seat (88), O-ring (72), Back-up Rings (25), Steel Ball (87) and Valve Spring (84). Replace if necessary.
  - c) Worn or damaged Piston Assembly (31): Inspect O-ring (33), O-ring (35) and Back-up Rings (93). Replace if necessary.
- 5 *Hydraulic fluid exhausts with air or leaks at base of handle.*
  - a) Worn or damaged Gland Assembly (54), inspect Variseal (61), O-rings (55, 56 & 58), Quad-ring (48) and Back-up Ring (57). Replace if necessary.
6. *Hydraulic fluid leaks at rear of Pull Piston (11)*
  - a) Worn or damaged Rear Gland (94): Inspect O-rings (16 & 18) and Back-up Rings (17 & 19). Replace if necessary.
7. *Hydraulic fluid leaks at front of Pull Piston (11).*
  - a) Worn or damaged Front Gland : Inspect Polyseal (10). Replace if necessary.
8. *Pull Piston (11) will not return.*
  - a) Throttle Valve (36) stuck: Lubricate O-rings (37 & 39).
  - b) Throttle Arm (66), Cable (2) or Trigger (3) binding.
9. *Air leaks at air Cylinder Head (49).*
  - a). Worn or damaged O-ring (48). Replace if necessary.

# ACCESSORIES

Stall Nut (Fig. 7)	-	120824
Pintail Collection Bag	-	125655
Service Tool Kit	-	126104
<i>Includes:</i>		
Assembly Bullet (Fig. 2)	-	123111-1
Spacer (Fig. 2)	-	123112-1



# LIMITED WARRANTIES

**Tooling Warranty:** Huck warrants that tooling and other items (excluding fasteners, and hereinafter referred as "other items") manufactured by Huck shall be free from defects in workmanship and materials for a period of ninety (90) days from the date of original purchase.

**Warranty on "non standard or custom manufactured products":** With regard to non-standard products or custom manufactured products to customer's specifications, Huck warrants for a period of ninety (90) days from the date of purchase that such products shall meet Buyer's specifications, be free of defects in workmanship and materials. Such warranty shall not be effective with respect to non-standard or custom products manufactured using buyer-supplied molds, material, tooling and fixtures that are not in good condition or repair and suitable for their intended purpose.

**THERE ARE NO WARRANTIES WHICH EXTEND BEYOND THE DESCRIPTION ON THE FACE HEREOF. HUCK MAKES NO OTHER WARRANTIES AND EXPRESSLY DISCLAIMS ANY OTHER WARRANTIES, INCLUDING IMPLIED WARRANTIES AS TO MERCHANTABILITY OR AS TO THE FITNESS OF THE TOOLING, OTHER ITEMS, NONSTANDARD OR CUSTOM MANUFACTURED PRODUCTS FOR ANY PARTICULAR PURPOSE AND HUCK SHALL NOT BE LIABLE FOR ANY LOSS OR DAMAGE, DIRECTLY OR INDIRECTLY, ARISING FROM THE USE OF SUCH TOOLING, OTHER ITEMS, NONSTANDARD OR CUSTOM MANUFACTURED PRODUCTS OR BREACH OF WARRANTY OR FOR ANY CLAIM FOR INCIDENTAL OR CONSEQUENTIAL DAMAGES.**

Huck's sole liability and Buyer's exclusive remedy for any breach of warranty shall be limited, at Huck's option, to replacement or repair, at FOB Huck's plant, of Huck manufactured tooling, other items, nonstandard or custom products found to be defective in specifications, workmanship and materials not otherwise the direct or indirect cause of Buyer supplied molds, material, tooling or fixtures. Buyer shall give Huck written notice of claims for defects within the ninety (90) day warranty period for tooling, other items, nonstandard or custom products described above and Huck shall inspect products for which such claim is made.

**Tooling, Part(s) and Other Items not manufactured by Huck.**

**HUCK MAKES NO WARRANTY WITH RESPECT TO THE TOOLING, PART(S) OR OTHER ITEMS MANUFACTURED BY THIRD PARTIES. HUCK EXPRESSLY DISCLAIMS ANY WARRANTY EXPRESSED OR IMPLIED, AS TO THE CONDITION,**

**DESIGN, OPERATION, MERCHANTABILITY OR FITNESS FOR USE OF ANY TOOL, PART(S), OR OTHER ITEMS THEREOF NOT MANUFACTURED BY HUCK. HUCK SHALL NOT BE LIABLE FOR ANY LOSS OR DAMAGE, DIRECTLY OR INDIRECTLY, ARISING FROM THE USE OF SUCH TOOLING, PART(S) OR OTHER ITEMS OR BREACH OF WARRANTY OR FOR ANY CLAIM FOR INCIDENTAL OR CONSEQUENTIAL DAMAGES.**

The only warranties made with respect to such tool, part(s) or other items thereof are those made by the manufacturer thereof and Huck agrees to cooperate with Buyer in enforcing such warranties when such action is necessary.

Huck shall not be liable for any loss or damage resulting from delays or nonfulfillment of orders owing to strikes, fires, accidents, transportation companies or for any reason or reasons beyond the control of the Huck or its suppliers.

## ***Huck Installation Equipment***

Huck International, Inc. reserves the right to make changes in specifications and design and to discontinue models without notice.

Huck Installation Equipment should be serviced by trained service technicians only.

Always give the Serial Number of the equipment when corresponding or ordering service parts.

Complete repair facilities are maintained by Huck International, Inc. Please contact one of the offices listed below.

### Eastern

One Corporate Drive Kingston, New York 12401-0250  
Telephone (845) 331-7300 FAX (845) 334-7333

### Canada

6150 Kennedy Road Unit 10, Mississauga, Ontario, L5T2J4, Canada.  
Telephone (905) 564-4825 FAX (905) 564-1963

### Outside USA and Canada

Contact your nearest Huck International Office, see back cover.

In addition to the above repair facilities, there are Authorized Tool Service Centers (ATSC's) located throughout the United States. These service centers offer repair services, spare parts, Service Parts Kits, Service Tools Kits and Nose Assemblies. Please contact your Huck Representative or the nearest Huck office listed on the back cover for the ATSC in your area.



**For the Long Haul™**

## A Global Organization

Alcoa Fastening Systems (AFS) maintains company offices throughout the United States and Canada, with subsidiary offices in many other countries. Authorized AFS distributors are also located in many of the world's

industrial and Aerospace centers, where they provide a ready source of AFS fasteners, installation tools, tool parts, and application assistance.

## Alcoa Fastening Systems world-wide locations:

### Americas

#### **Alcoa Fastening Systems**

##### Aerospace Products

##### Tucson Operations

3724 East Columbia  
Tucson, AZ 85714  
800-234-4825  
520-747-9898  
FAX: 520-748-2142

#### **Alcoa Fastening Systems**

##### Aerospace Products

##### Carson Operations

PO Box 5268  
900 Watson Center Rd.  
Carson, CA 90749  
800-421-1459  
310-830-8200  
FAX: 310-830-1436

#### **Alcoa Fastening Systems**

##### Commercial Products

##### Waco Operations

PO Box 8117  
8001 Imperial Drive  
Waco, TX 76714-8117  
800-388-4825  
254-776-2000  
FAX: 254-751-5259

#### **Alcoa Fastening Systems**

##### Commercial Products

##### Kingston Operations

1 Corporate Drive  
Kingston, NY 12401  
800-431-3091  
845-331-7300  
FAX: 845-334-7333  
www.hucktools.com

#### **Alcoa Fastening Systems**

##### Commercial Products

##### Canada Operations

6150 Kennedy Road, Unit 10  
Mississauga, Ontario L5T2J4  
Canada  
905-564-4825  
FAX: 905-564-1963

#### **Alcoa Fastening Systems**

##### Commercial Products

##### Latin America Operations

Avenida Parque Lira. 79-402  
Tacubaya Mexico, D.F.  
C.P. 11850  
FAX: 525-515-1776  
TELEX: 1173530 LUKSME

### Far East

#### **Alcoa Fastening Systems**

##### Commercial Products

##### Australia Operations

14 Viewtech Place  
Rowville, Victoria  
Australia 3178  
03-764-5500  
Toll Free: 008-335-030  
FAX: 03-764-5510

### Europe

#### **Alcoa Fastening Systems**

##### Commercial Products

##### United Kingdom Operations

Unit C, Stafford Park 7  
Telford, Shropshire  
England TF3 3BQ  
01952-290011  
FAX: 0952-290459

#### **Alcoa Fastening Systems**

##### Aerospace Products

##### France Operations

Clos D'Asseville  
BP4  
95450 Us Par Vigny  
France  
33-1-30-27-9500  
FAX: 33-1-34-66-0600



For The Long Haul, The Future of Fastening Technology, The Future of Assembly Technology, The Future of Tooling Technology, and Tools of Productivity are service marks of Huck International. Huck provides technical assistance regarding the use and application of Huck fasteners and tooling.

NOTICE: The information contained in this publication is only for general guidance with regard to properties of the products shown

and/or the means for selecting such products, and is not intended to create any warranty, express, implied, or statutory; all warranties are contained only in Huck's written quotations, acknowledgements, and/or purchase orders. It is recommended that the user secure specific, up-to-date data and information regarding each application and/or use of such products.

HWB898 1003-5M

# Alcoa Fastening Systems



One Great Connection<sup>SM</sup>